

YAESU

FT-102

HF transceiver



SURVIVAL GUIDE

WIDE CLEAN

- * Unique recessible controls for VOX GAIN, DELAY, MIC GAIN, processor COMP, NB LEVEL and FM SQL are normally flush with the front panel. Just touch the knob and it pops out for adjustment, and press it back in out of the way when set.
- * The NB LEVEL control actually adjusts the width of the noise blanking pulse, giving incredible versatility to remove a wide variety of noise.
- * The NAR button conveniently selects the optional narrow filters for the mode (SSB or CW) selected by the MODE selector.
- * The RF AMP button can be pressed when band noise is high or strong signals are being worked, bypassing the RF amplifier and pushing the dynamic range over 100dB.
- * Press the MONI button to monitor the IF of the transmitter when tuning up or adjusting microphone audio response. You can precisely adjust the RF processor while listening to the actual processor output.
- * While speaking into the microphone, press a button to activate the ALC Peak Hold system, causing the ALC meter needle to stop right at peak ALC automatically and allowing truly accurate transmit level setting.
- * Dual meters allow much more all round operating convenience, and become indispensable for truly precise adjustment and monitoring of the RF speech processor.
- * An IF Notch system and a Audio Peak Filter are selected and tuned independently. Both can be used at the same time, if desired.
- * Friction-ganged IF Shift/Width controls allow the operator to select the optimum bandwidth for band conditions and mode, and then to tune this "window" across the incoming signal. Say goodbye to QRM.
- * Novel chassis design and rugged cabinet constructed so that the FT-102 is more compact than any other transceiver/power supply combination in its class (only 310 mm deep).



This manual is a courtesy to you from **Fox-Tango International**, with contributions from Carol W4CLM, Mal NC4L, José EB5AGV, Wim PA0PGA, and many other FT-102 lovers.

DYNAMIC RANGE TRANSMITTER OUTPUT



This manual is a courtesy to you from **Fox-Tango International**, with contributions from Carol W4CLM, Mal NC4L, José EB5AGV, Wim PA0PGA, and many other FT-102 lovers.

FT-102 HIGH PERFORMANCE HF TRANSCEIVER



Better Dynamic Range

The extra high-level receiver front end uses 24 VDC for both RF amplifier and mixer circuits, allowing an extremely wide dynamic range for solid copy of the weak signals even in the weekend crowds. For ultra clear copy on strong signals or noisy bands the high voltage JFET RF amplifier can be simply bypassed via a front panel switch, boosting dynamic range beyond 100 dB. A PLL system using six narrow band VCOs provides exceptionally clean local signals on all bands for both transmit and receive.

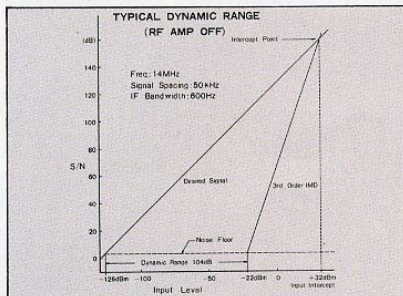
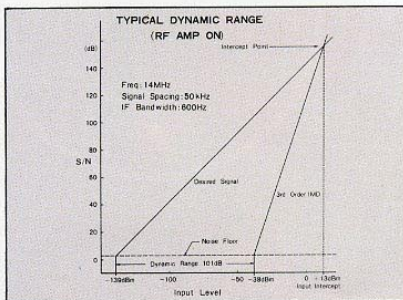

Total IF Flexibility

An extremely versatile IF Shift/Width system, using friction-linked concentric controls and a totally unique circuit design, gives the operator an infinite choice of bandwidths between 2.7 kHz and 500 Hz, which can then be tuned across the signal to the portion that provides the best copy sans QRM, even in a crowded band. A wide variety of crystal filters for fixed IF bandwidths are also available as options for both parallel and cascaded configurations. But that's not all; the 455 kHz third IF also allows an extremely effective IF notch tunable across the selected passband to remove interfering carriers, while an independent audio peak filter can also be activated for single-signal CW reception.

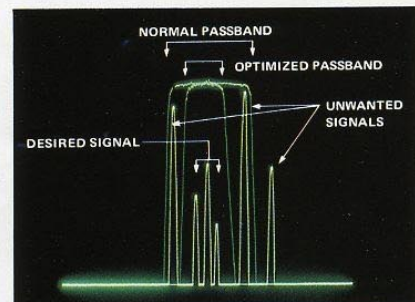

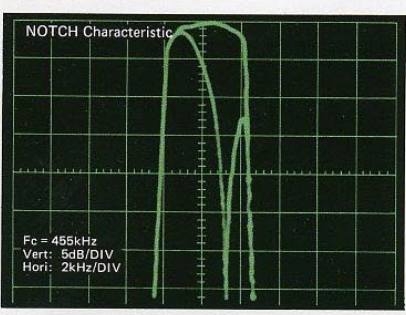
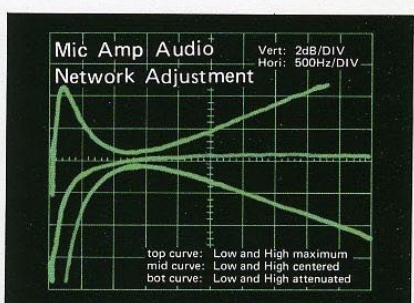
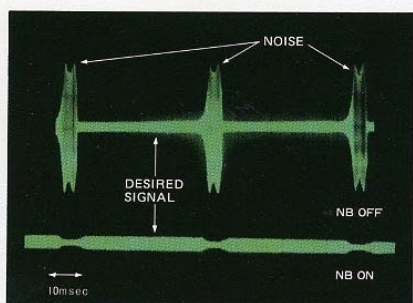
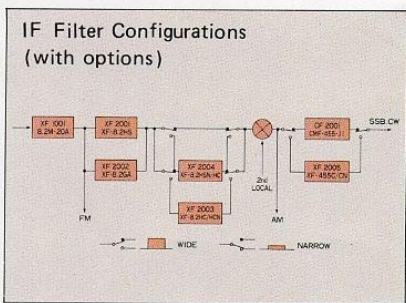

New Noise Blanker

The new noise blanker design in the FT-102 enables front panel control of the blanking pulse width, substantially increasing the number of types of noise interference that can be blanked, and vastly improving the utility of the noise blanker for all types of operation, including woopecker blanking.

Commercial Quality Transmitter

The FT-102 represents significant strides in the advancement of amateur transmitter signal quality, introducing to amateur radio design concepts that have previously been restricted to top-of-the-line commercial transmitters; far above and beyond government standards in both freedom from distortion and purity of emissions.

Transmitter Audio Tailoring

The microphone amplifier circuit incorporates a tunable audio network which can be adjusted by the operator to tailor the transmitter response to his individual voice characteristic before the signal is applied to the superb internal RF speech processor.

New Standard of Purity

Three 6146B final tubes in a specially configured circuit provide a freedom from IMD products and an overall purity of emission unattainable in two-tube and transistor designs, while a new DC fan motor gives whisper-quiet cooling as a standard feature. For the amateur who wants a truly professional quality signal, the answer is the Yaesu FT-102.



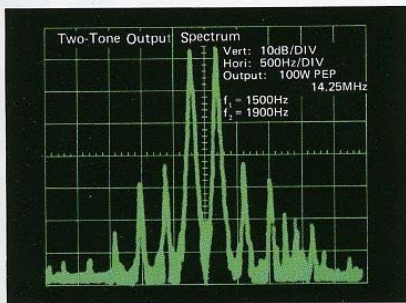

IF Transmit Monitor

An extra product detector allows audio monitoring of the transmitter IF signal, which, along with dual meters on the front panel, enables precise setting of the speech processor and transmit audio so that the operator knows exactly what signal is being put on the air in all modes. A new "peak hold" system is incorporated into the ALC metering circuit to further take the guesswork out of transmitter adjustment.

New VFO Design

Using a new IC module developed especially for Yaesu, the VFO in the FT-102 exhibits exceptional stability under all operating conditions. The circuit design accommodating the new module is extremely simple, using only axial-lead components, and vastly decreasing the number of discrete components that can cause instability or fail in conventional analog and digital designs. The VFO circuit is encased in a heavy, cast-aluminum housing to prevent interaction with other circuits.

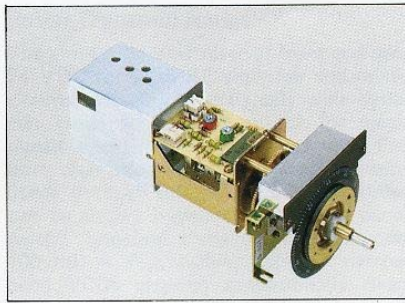

Versatile Applications

The rear panel includes jacks for an external spotting receiver and separate receive antenna for serious contesting and low band operation, while a single AM/FM Unit that enables operation on both additional modes is available as an option. The extensive new line of accessories developed for the FT-102 continue Yaesu's tradition of giving you the choice of the features your operating needs call for, without paying for "standard features" you don't need.

FV-102DM Synthesized, Scanning External VFO

The FV-102DM provides the FT-102 with the advanced frequency control necessary for optimum operating convenience, especially in DX and contest situations where seconds count. The PLL synthesizer steps at a 10 Hz rate, while slow or fast scanning can be controlled either from the push buttons on the front panel or directly from the microphone connected to the FT-102

(when a scanning microphone is used). Up to twelve frequencies can be memorized by the FV-102DM, entered from the FT-102, FV-102DM VFO or from the front panel numerical keyboard. Additional front panel controls include plus-and-minus 5 kHz and plus-and-minus 20 kHz stepping buttons; VFO dial lock, last digit blanking, and transmit/receive Main/VFO/ memory selector buttons to allow any combination of frequency controls. The VFO dial can also be activated as a clarifier for a selected memory, while the five digit fluorescent display shows the operating frequency with resolution to 10 Hz, if desired.

FC-102 Antenna Coupler

The FC-102 is a newly designed antenna tuner ideally suited for use with the FT-102 station. With a power handling capability of 1.2 kW, the bandswitched L-C pi-network will match a wide variety of antennas (including a single wire) to your transceiver or linear amplifier on all HF amateur bands. New design features include an in-line wattmeter with three ranges (20, 200, and 1200 watts full scale), and a "peak hold" system that enables the operator to observe peak power with ease. A separate SWR meter is also built in for antenna tuning indication. The FC-102 includes internal relays to provide low-loss pushbutton selection of two different antennas (and two transmitters), while the optional FAS-1-4R Remote Antenna Selector may be mounted either inside the FC-102 or right on your tower, to allow selection of four additional antennas. When remotely installed, the FAS-1-4R is connected by a control line to the FC-102, eliminating the need for costly multiple

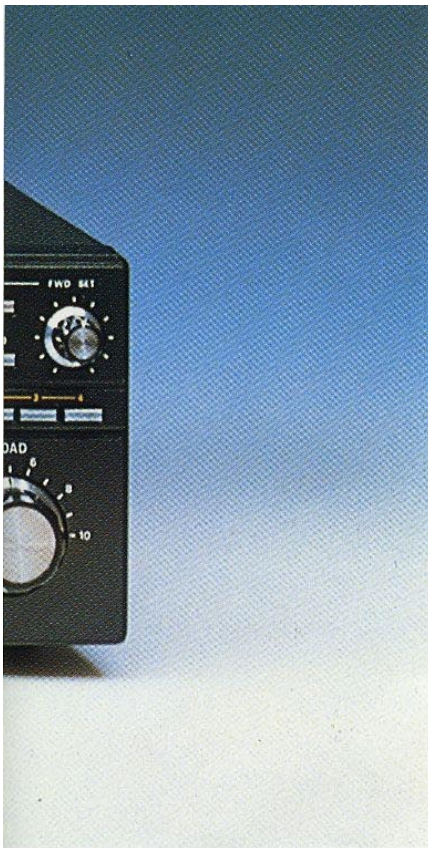

feedlines. Contained within the diecast weatherproof housing of the FAS-1-4R are four independent relays to ensure low loss and excellent isolation.

SP-102 External Speaker/Audio Filter

The SP-102 features a large (120 mm) high-fidelity speaker with selectable low- and high-cut audio filters allowing twelve possible response curves. Headphones may also be connected to the SP-102 to take advantage of the filtering feature, which allows audio tailoring for each bandwidth and mode of operation to obtain optimum readability under a variety of conditions. Two input jacks are provided, selectable from the front panel.

SP-102P External Speaker/Phone Patch

The attractive styling of the SP-102P matches the FT-102, providing a combination shaped response speaker and hybrid phone patch for simple interfacing of the FT-102 with telephone systems. Gain controls and an audio level meter are included on the SP-102P, while interconnections are designed specifically to mate easily with the FT-102.



SPECIFICATIONS

GENERAL

Frequency coverage:

Band	Range
1.8	1.8 – 2.0 MHz
3.5	3.5 – 4.0 MHz
7	7.0 – 7.5 MHz
10	10.0 – 10.5 MHz*
14	14.0 – 14.5 MHz
18	18.0 – 18.5 MHz
21	21.0 – 21.5 MHz
24.5	24.5 – 25.0 MHz
28, 29	28.0 – 29.9 MHz

Operating Modes:

LSB, USB (A3J/J3E); CW (A1/A1A); AM (A3/A3E) and FM (F3/F3E)**

Power requirements:

100, 117, 200, or 234 VAC, 50/60 Hz

Power consumption:

Receive; 95 VA (73 VA with heaters off)
Transmit; 350 VA (for 100W output)

Dimensions (WHD):

368 x 129 x 310 mm

Weight:

Approx. 15 kg.

TRANSMITTER

Power Input:

(1.8 – 25 MHz) (28 – 29.9 MHz)

SSB, CW	240W DC	160W DC
AM**	80W DC	80W DC
FM**		160W DC

Carrier suppression:

Better than -40 dB at 14 MHz

Sideband suppression:

Better than -60 dB (14 MHz, 1 kHz tone)

Spurious Radiation:

Better than -40 dB

Transmitter audio frequency response:

300 – 2900 Hz (-6 dB) adjustable

Third order intermodulation products:

Better than -40 dB (14 MHz, 100W PEP)

Negative feedback level:

Approx. -8 dB at 14 MHz

Frequency stability:

Less than 300 Hz drift during the first 30 minutes after 10 minutes warm-up; less than 100 Hz every 30 minutes thereafter

Modulation types:

A3J/J3E: balanced modulator
A3/A3E: low level amplitude modulator
F3/F3E: variable reactance modulator

Microphone input impedance:

Low, 200 to 600 ohms

RECEIVER

Image rejection:

Better than 70dB from 1.8 – 21.5MHz
Better than 50dB from 24.5 – 29.9MHz

IF rejection:

Better than 70 dB

AF Output:

1.5 W minimum (8 ohms, 10% THD)

AF Output impedance:

4 – 16 ohms

Selectivity (-6 dB/-60 dB):

SSB, CW, AM; 2.7/4.8 kHz (with no optional filters)
Width adjusts continuously from 2.7 kHz to 500 Hz (-6 dB)

Options:

SSB nar., CW wide; 1.8/3.1 kHz with XF-8.2 HSN filter

CW nar.; 600/1300 Hz with XF-8.2HC filter

CW nar.; 300/800 Hz with XF-8.2HCN filter

CW nar.; 500/1100 Hz with XF-455C filter

CW nar.; 270/600 Hz with XF-455CN filter

AM; 6/12.4 kHz with XF-8.2GA filter

IF Notch depth:

Better than 40 dB

Sensitivity (worst case, in μV for 10 dB (S+N)/N, except FM):

(RF AMP ON) (RF AMP OFF)

SSB (no optional filters)

0.25 1.0

CW (no optional filters)

0.18 0.7

AM (no optional filters)

1.0 4.0

FM** (for 20 dB quieting)

0.4 3.0

CW (with APF on)

0.05 0.2

SSB (with XF-8.2HSN filter installed)

0.2 0.8

CW (with XF-8.2HC filter installed)

0.12 0.5

Dynamic range (with Shift/Width Control set for maximum IF width, 14 MHz):

(RF AMP ON) (RF AMP OFF)

With no optional filters

90 dB minimum 95 dB minimum

With XF-8.2HC installed

95 dB minimum 100 dB minimum

With XF-8.2HCN installed

97 dB minimum 102 dB minimum

* No reception at 10.33 MHz ($f_{L01} - f_{L02}$)

** Optional AM/FM Unit required for AM transmission and FM operation.



Specifications are subject to change without notice due to design changes.

New Yaesu FT-102 Series Transceiver of Champions!



The long-awaited new generation of Yaesu HF technology has arrived! New research in improved receiver filtering and spectral purity is brought to bear in the competition-bred FT-102, the HF transceiver designed for active Amateurs on today's intensely active bands!

Unique Cascaded Filter System

The FT-102 utilizes an advanced 8.2 MHz and 455 kHz IF system, capable of accepting as many as three filters in cascade. Optional filters of 2.9 kHz, 1.8 kHz, 600 Hz, and 300 Hz may be combined with the two stock 2.9 kHz filters for operating flexibility you've never seen in an HF transceiver before now!

All New Receiver Front End

Utilizing husky junction field-effect transistors in a 24 volt, high-current design, the FT-102 front end features a low-distortion RF preamplifier that may be bypassed via a front panel switch when not needed.

IF Notch and Audio Peak Filter

A highly effective 455 kHz IF Notch Filter provides superb rejection of heterodynes, carriers, and other annoying interference appearing within the IF passband. On CW, the Audio Peak Filter may be switched in during extremely tight pile-up conditions for post-detection signal enhancement.

Variable IF Bandwidth with IF Shift

The FT-102's double conversion receiver features Yaesu's time-proven Variable Bandwidth System, which utilizes the cascaded IF filters to provide intermediate bandwidths such as 2.1 kHz, 1.5 kHz, or 800 Hz simply by twisting a dial. The Variable Bandwidth System is used in conjunction with the IF Shift control, which allows the operator to center the IF passband frequency response without varying the incoming signal pitch.

Wide/Narrow Filter Selection

Depending on the exact combination of optional filters you choose, a variety of wide/narrow operating modes may be selected. For example, you may set up 2.9 kHz in SSB/WIDE, 1.8 kHz in SSB/NARROW, then select 1.8 kHz for CW/WIDE, and 600 Hz or 300 Hz for CW/NARROW. Or use the Variable Bandwidth to set your SSB bandwidth, and use 600 Hz for CW/WIDE and 300 Hz for CW/NARROW! No other manufacturer gives you so much flexibility in selecting filter responses!

Variable Pulse Width Noise Blanker

Ignition noise, the "Woodpecker," and power line noise are modern-day enemies of effective Amateur operation. The FT-102 Noise Blanker offers improved blanking action on today's man-made noise sources (though no blanker can eliminate all forms of band noise) for more solid copy under adverse conditions.

Low Distortion Audio/IF Stage Design

Now that dynamic range, stability, and AGC problems have been largely eliminated thanks to improved technology, Yaesu's engineers have put particular attention on maximizing intelligence recovery in the receiver. While elementary filter cascading schemes often degrade performance, the FT-102's unique blend of crystal and ceramic IF filters plus audio tone control provides very low phase delay, reduced passband ripple, and hence increased recovery of information.

Heavy Duty Three-Tube Final Amplifier

The FT-102 final amplifier uses three 6146B tubes for more consistent power output and improved reliability. Using up to 10 dB of RF negative feedback, the FT-102 transmitter third-order distortion products are typically 40 dB down, giving you a studio quality output signal.

Dual Metering System

Adopted from the new FT-ONE transceiver, the Dual Metering System provides simultaneous display of ALC voltage on one meter along with metering of plate voltage, cathode current, relative power output, or clipping level on the other. This system greatly simplifies proper adjustment of the transmitter.

Microphone Amplifier Tone Control

Recognizing the differences in voice characteristics of Amateur operators, Yaesu's engineers have incorporated an ingenious microphone amplifier tone control circuit, which allows you to tailor the treble and bass response of the FT-102 transmitter for best fidelity on your speech pattern.

RF Speech Processor

The built-in RF Speech Processor uses true RF clipping, for improved talk power under difficult conditions. The clipping type speech processor provides cleaner, more effective "punch" for your signal than simpler circuits used in other transmitters.

VOX with Front Panel Controls

The FT-102 standard package includes VOX for hands-free operation. Both the VOX Gain and VOX Delay controls are located on the front panel, for maximum operator convenience.

IF Monitor Circuit

For easy adjustment of the RF Speech Processor or for recording both sides of a conversation, an IF monitor circuit is provided in the transmitter section. When the optional AM/FM unit is installed, the IF monitor may be used for proper setting of the FM deviation and AM mic gain.

WARC Bands Factory Installed

The FT-102 is factory equipped for operation on all present and proposed Amateur bands, so you won't have to worry about retrofitting capability on your transceiver. An extra AUX band position is available on the bandswitch for special applications.

Full Line Of Accessories

For maximum operating flexibility, see your Authorized Dealer for details of the complete line of FT-102 accessories. Coming soon are the FV-102DM Synthesized VFO, SP-102 Speaker/Audio Filter, a full line of optional filters and microphones, and the AM/FM Unit.

Price And Specifications Subject To
Change Without Notice Or Obligation

YAESU
The radio.



This manual is a courtesy to you from **Fox-Tango International**, with contributions from Carol W4CLM, Mal NC4L, José EB5AGV, Wim PA0PGA, and many other FT-102 lovers.

The FT-102, Transceiver of Champions

Introduction by PA0PGA



The Yaesu FT-102 was introduced in 1982 as the next descendant of the immensely popular FT-101ZD and FT901/902DM series transceivers. The new Yaesu FT-102 was setting another milestone in Yaesu's very successful line of HF transceivers, together with the FT-One, the flagship of the line.

The FT-102 is a self-contained transceiver, including the powersupply, a PA with a lot of punch, and a very sensitive receiver. The look resembles somewhat the look of the high-end audio equipment of the time, black and silver, but very stylish done, it remains a beautiful piece of equipment even after some 25 years.

The receiver of the FT-102 has an excellent sensitivity and can handle very big signals distortion free, due to the special developed RF and Mixer stages. The dynamic range is about –135db, measured in several tests, a unique feat for an off-the-shelf transceiver of this age. Even the newest transceivers in the 10 kilobuck range can not surpass this. !

The receiver uses a dual IF stage, with excellent filtering, with even 3 cascaded filters possible, so the selectivity can really be awesome. Using a special mixing technique, it is possible to vary the bandwidth of the IF continuously and place the filter at any place in the main passband, for eliminating low or high pitched noise, cutting down the QRM as much as possible, the best you could get in the pre-DSP days.

The IF has 2 stages 8.2 Mhz and 455khz, which allows for a beautifully recovered audio, in fact the FT-102 has the best audio I ever heard.

The TX side is just as impressive, with a very beautiful audio quality. It allows adjustments to make the most from your voice and the used microphone.

RF feedback from the PA stage allows for a very clean RF signal and the PA with 3x 6146B tubes deliver a solid 120 Watts to the antenna.

Everywhere in this set you can see that there was no compromise made by the Yaesu engineers, and the resulting FT-102 is really a masterpiece, that deserves to survive the next 25 years or so, which is easily possible with some loving care of the big group of Yaesu FT-102 lovers.

In this Survival Guide we will try to collect in one volume all you need to know about keeping this excellent transceiver in a perfect condition for a long time to come.

The FT-102 was introduced late in 1982, and was produced till the end of 1984, and was then replaced by the very popular FT-757GX, who uses a solidstate PA, so there was no PA and preselector tuning necessary anymore. Tubes were on their way out anyway in 1984, there were less and less tubes produced

and the demand for transistor PA's forced Yaesu to close production of the FT-102 in favor of the new FT-757GX.

I don't know how many of the FT-102 were produced, but they are a rather common find on the internet auction sites, although for a rather high price. (And prices tend to go up every year !)

So, if you be able to obtain one in good condition at a fair price: Grab it, you will not be sorry, and if you want to sell it later, it will bring back your money, if not more.

OK, there are some issues with the signal relays in this sets, but they are still available, and not difficult to replace. If you replace them with miniature Teledyne relays, there are no problems anymore in your lifetime.

For the rest: Every Oldtimer needs some attention, be it a radio, a car or a motorcycle, and that is just a part of the fun. Parts are easily available or can be substituted. Internet is really a great source, because you can shop all over the world. I have purchased parts from all over the world, with no problems whatever. It is just as easy to buy in Australia or elsewhere, as it is locally.

The time that there was an electronic shop in every town, is really gone, but if you search the Internet, you find some very good sources for "obsolete" parts.

And if you need help: Members of the FoxTango group are always there to help you out in trouble or if you are confused by some unexpected issue. Try them, they are really a great bunch.

For all facts and knowledge, put in this Survival Guide we will thank the original authors for letting us use their material. They are Hams with the right spirit and have much expertise. So follow their tips and keep your FT-102 in the air !!

We will try to update this manual from time to time, if we have collected new material, so if you like to contribute to this Survival Guide, send your material to Carol W4CLM, or to Wim Penders PA0PGA (wpenders@[-remove-home.nl](mailto:wpenders@-remove-home.nl)), for including in the next update.

Thanks in advance.

I hope you will enjoy the next pages, and maybe you will be a wiser (wo)man when finished.

73, Wim Penders PA0PGA



From the FT-102 pages of Carol Maher W4CLM

Introduced in 1982, the FT-102 is one of the finest amateur radio transceiver ever made for its time and still remains an excellent option to buying a more modern Multi~Kilo~Buck transceiver produced now being manufactured in the 21st century. Unfortunately for the FT-102 it did not last very long insofar as the US market. By years end (1984) Yaesu was clearing the way for other transceivers like the FT-757GX. Good marketing, dictates not having too many models from the same manufacturer competing with each other. Sporting three 6146 in the final amplifier stage can have its advantages over that of transistors. The concept of of the 3-tube final amplifier with negative feedback was indeed revolutionary for the amateur market, however tube type transceiver were on their way out by the mid 1980s and eventually the FT-102 was discontinued. The rig remains a favorite among those who have used them and it maintains a cult like following by those users in the know even to this day.



One of the first things that you notice about the FT-102 is it's use of three 6146 final amplifier tubes in the final amplifier tank circuit. The forgiving nature of the three 6146 finals to an occasional high VSWR with full output gives one peace of mind not always enjoyed by completely solid-state transceivers. The three 6146 tubes gives the FT-102 more consistent power output and improved reliability over tube transceivers produced in the past such as the FT-101 with its sweep tube finals. The FT-102 claims 10db of negative feedback with third order distortion of 40db down giving the transceiver one of the best sounding audio of any transceiver ever produced without the use of studio equalizers in use by the (ESSB) enhanced SSB audio crowd found on the amateur bands of today. My experience with this transceiver is that the longer its on the better it sounds and audio reports are fantastic.



Another eye catching feature of the FT-102 similar to the of the Yaesu FT-One, is its use of a dual front panel metering. The dual metering system provide simultaneous display of ALC voltage on one meter, along with monitoring of plate voltage, cathode current, power output and compression level of the processor on the multi meter providing for simplified monitoring of the transmitter PA. When it comes to knowing the FT-102, most likely the number one person in the county on this rig is Malcolm Eisman NC4L (Mal), one can hardly talk about the FT-102 without his name coming up. Malcolm came up with a nice modification for the meter lamps as noted in the photos below.

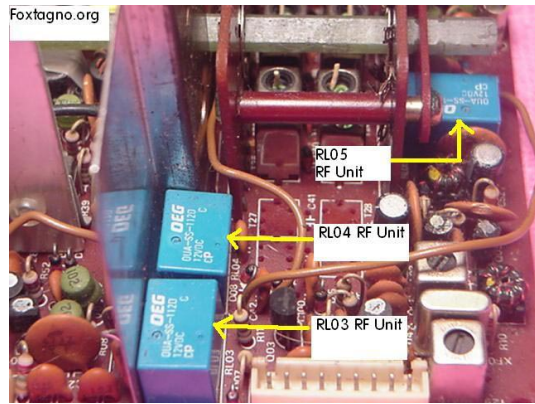

Everything you ever want to know about FT-102 Relays.

The Truth About FT-102 Relays !

When it comes to the FT-102 transceiver the first topic that pops into one's head is **RELAYS!**

The first thing you always hear about regarding the FT-102 is just how bad the relay situation is! I really beg to differ on this because it usually winds up being only one or two relays out of the whole set that give you a problem, thus the general opinion is that all the relays are faulty. That will not be the case, but either way you look at it these rigs are now going on some 24+ years old so you really can't go wrong replacing them all. If you need a set, See the Fox Tango Club Candy Store for our FT-102 Relay Replacement Pack. Also see Installing New Relays In Your FT-102. In an effort to clear up any misunderstanding about the FT-102 and the relays we will take a look at each individual relay its replacement and or modifications for replacements. The relay that is most commonly seen relay in the FT-102 RF Unit PB-2342 is (RL01, RL03, RL04, RL05) if your transceiver has the original small blue cube relays as shown in the photo above these were made OEG Relays (TYCO Electronics) the more commonly used replacement part for these relays is the OMRON G2E-184P. The relay is a miniature, low cost single-pole 12 VDC relay . Pretty straight forward in that it is wired for normally open (N/O or normally closed (N/C) contact. You should make note of the following, so FT-102 were modified so that RL04 and RL05 are wired for 24vdc, see notes below for more on this.

Omron G2E-184P-M See: Omron G2E data sheet here. If Yaesu USA has any left the part number as of 1/12/06 was M1190032 at a cost of \$4.50 each when they were available from Yaesu parts, but they no longer carry these in current stock.

See figure "A" to the left side. As noted you will find four of these on the RF Unit PB-2342, one on the IF Unit, one on the local unit and lastly one on the final board (*needs to be removed) just under the 6146 tube sockets. All can be replaced with the OMRON relay G2E-184P-M fully sealed 12vdc relay which can easily be found in the United States. There has been some discussion as to a modification where RL-04 and RL-05 on the RF Unit are wired together in series for 24Vdc operation. There is some controversy about this as to whether or not one should use the 24 Vs 12 volt relays. My gut feeling on this is to leave the relays as original set up for 12Vdc. After discussing this subject with Malcolm (NC4L) the FT-102 Guru here in the USA, he believes the 24vdc modification to the RF Unit was used for a ballast for the front end supply. In other words instead of using the 12 volt supply for the relays - they found that the DC for the front end was better slightly loaded down. The circuit for the 24 volts is not the most sophisticated or precision item as it is only zener regulated. As per Malcolm "they looked around and figured - lets power two relays with the front end supply so that the energy for the loading effect at least has a useful purpose. I am pretty sure that was the case as they certainly have an ample amount of 12 volt power to run the relays." My gut feeling on this subject is to leave the rig alone, if it's wired for individual 12Vdc relays and the transceiver remains operation, then don't fix what is not broken.

Other Cross References for the G2E
 FUJITSU: FBR211SC/SE
 OEG: OUA/OUAZ OUA-SS-124D
 SIEMENS: A/B201/V23101
 GEI LS1-012-6L1S

RF Unit PB-2342B, 12 VDC Relays
 RL01, RL03, RL04, RL05

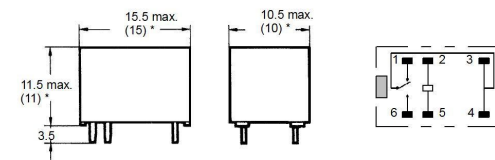

http://www.foxtango.org

Fig "A"

- OEG OUA-SS-112D
- OEG OUA-SS-124D
- FBR211A D012-M
- Omron G2E-184P-M
- Omron G2E-134P-M
- Omron G2E-187M

Board		Qty
RF Unit	PB-2342	4
IF Unit	PB-2343	1
Local Unit	PB-2345	1
Final Board	PB-2355	1



PCB Relay	G2E
------------------	------------

Miniature, Low-cost, Single-pole PCB Relay

- Miniature: 15.5 x 10.5 x 11.5 mm (L x W x H).
- Low power consumption: 200 mW.
- Bifurcated crossbar contacts.
- Gold-clad contacts.
- Fully sealed type available.
- Ideal for telecommunications equipment and security systems.



RC

Ordering Information

Contact	General-purpose		High-sensitivity
	Fully sealed		Fully sealed
SPDT	Single crossbar	G2E-184P-M-US	G2E-184P-HM-US
	Bifurcated crossbar	G2E-134P-M-US	G2E-134P-HM-US

Note: When ordering, add the rated coil voltage to the model number.
 Example: G2E-184P-M-US 12 VDC

Model Number Legend

G2E - □ □ □ □ □ □ □ □ □ □ VDC
 1 2 3 4 5 6 7 8

- | | | |
|---|--|--|
| 1. Contact Form
1: SPDT | 4. Terminal
P: Straight PCB | 8. Classification
M: General-purpose |
| 2. Contact Type
3: Bifurcated crossbar
8: Single crossbar | 5. Power Consumption
None: General-purpose (450 mW)
H: High-sensitivity (200 mW) | 7. Approved Standards
US: UL, CSA certified |
| 3. Enclosure Ratings
4: Fully sealed | | 8. Rated Coil Voltage
1.5, 3, 5, 6, 9, 12, 24 VDC |

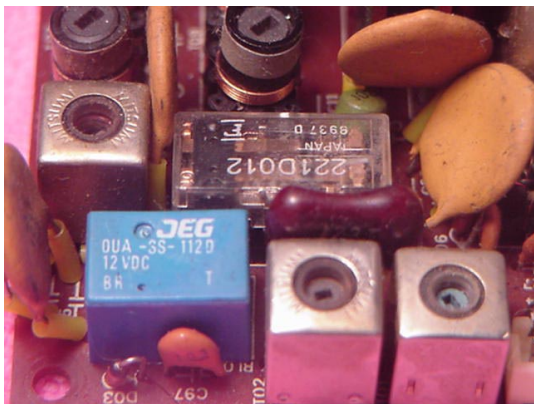

RL02 RF Unit PB2342.

This single relay in the FT-102 that stirs up the most controversy among those in the FT-102 community of users is that of RL02 on the RF unit as it is no longer available. Originally made by Fujitsu of Japan relay type FBR221A DO12 is shown below. Two schools of thought currently exist for repair or replacement of this relay. Currently however the club has a complete relay kit available for the FT-102 (Less RL1 & RL2) See: Fox Tango Candy Store for the FT-102 relay replacement kit. Check for availability as we only have a limited supply of original Fujitsu relays in a complete relay kit if you are in need of this part.

Yaesu part number for this item was P/N 70000031 (BR221D012) 12v they also made a 9 volt version of this relay P/N 70000034 (BR211AD009-M) 9v which could be modified for use in place of RL02 with a 3v voltage drop on the coil if it becomes necessary to resort to this.

First school of thought on this comes from Jose - (EB5AGV/EC5AAU) in Spain. Jose has come up with a most ingenious way of changing this relay over to a more commonly available Omron relay G6A-234P, See Jose's tutorial for relay replacement EB5AGV's FT-102 relay substitution TUTORIAL

You have got to give Jose credit for investigating a suitable replacement and in his ability to come up with a creative process for replacement of this hard to find relay.

The second school of thought on this matter comes from (NC4L) Malcolm (Mal) the undisputed guru of the FT-102 here in the United States. Mal has come up with an very intricate restoration process where by he finalizes the restoration by gold plating the relay contacts. See: www.members.aol.com/NC4LMal This procedure while time consuming manages to leave PB-2342 in it's original condition without modification.

The following I received from Mal in an Email 1/21/06

The procedure starts with the removal of the top of the relay and placing the relay in an ultrasonic cleaner to remove any particulate matter. The relay is then dried. After this the arms holding the contacts are bent back with special tools to expose the surfaces of the contacts. The small needle nose pliers that I use for this had to be fashioned with a Dremel tool and high speed diamond wheel which I used to get a rounded surface for the side of the pliers jaw. Without this remodeling, the flat surface of the jaw and the sharp angle at the side of the jaw leaves a crimp in the copper arm holding the contact. This crimp damages the arm and eventually causes the arm to fall off with the repeated flexion that comes with the operation of the relay.

With all the contacts openly exposed they are physically cleaned with a soft brass brush and the high speed Dremel tool until all the foreign matter is removed and the contacts are made bright and shiny.

Now comes the hard part. The copper arms holding the contacts which have been splayed back have to be gently returned to their original position and tensioned for proper force. I do this by hand and it is a very time consuming and exacting endeavor.

When this is completed the unit goes for its first gold plating. For half of the gold plating session the arms are held in the open position to get those contacts plated. Then the special plastic shim holding the contact open is removed and the unit is plated again to get the other two contacts.

The unit is again rinsed and dried before the conditioning process is started. This is done by repeatedly cycling the contacts with a high current flowing to all the contacts. I found that this is necessary to

RL02 installed on the RF Unit PB2342

Fujitsu type FBR221A

12VDC Relay RL02 Original FBR221A-D012

Board	Qty
RL02 RF Unit	1

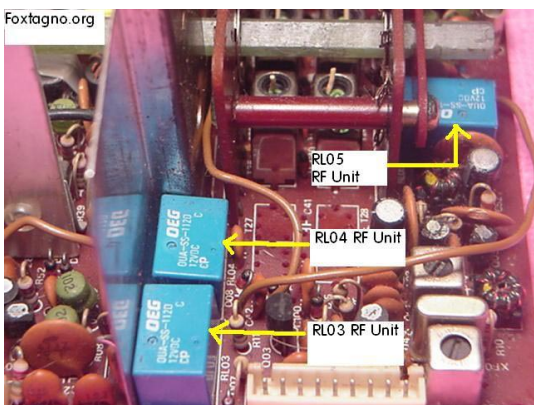
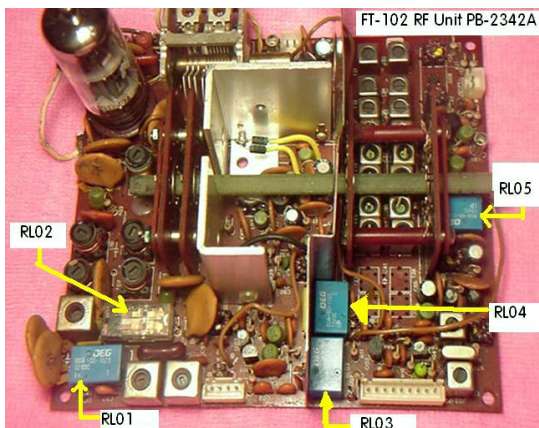

RF Unit RL02 Relay

reform the contacts since no matter how carefully I reposition and tension the arms the fit may not be perfect. This high current during the make and break cycle heats the metal of the contact and deforms it so that it fits precisely to the matching opposite half. Too few cycles will not give a good fit and too many will permanently damage the contacts. This information is proprietary so we will go on to the next step.

The unit is now replated for all four contacts in the gold solution bath so that the previously heated portions of the contacts from the conditioning process also gets a proper plating. The unit is again dried and the top replaced.

But you cry are we finished. The answer is not yet.

The last step is quality control where the unit is placed on a milliohm meter and cycled 50 times per contact. No one reading on any contact can exceed 50 milliohms (.05 ohm) or the unit is not acceptable.

For this auction and in my own repair work a special gold plated socket will be supplied to be installed so that if a problem occurred, the relay can be removed and replaced without dismantling the radio to unsolder it. However if you are brave just solder it in place as I am confident it will be and stay good.

Relay 02 is in close proximity to a transmit mixer that runs continuously in receive as well as transmit. That circuit is in the middle of the RF board (inside the metal baffle) on the upper side. Because of this other circuit the relay was meant to be flat to the surface the board to reduce cross modulation. I file the shoulders of the socket to get another millimeter closer to the plane of the board to reduce this interaction to a minimum. As mentioned above the special socket (which is also gold plated) is supplied with the auction.

Well, that about completes the description for this auction. Enjoy the photo below which will permit you to conceptualize the this process better.

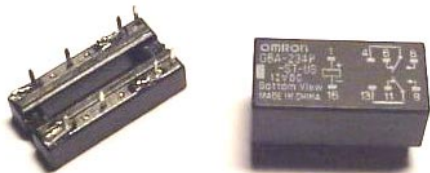

Some other points - a fellow ham in Spain has a modification where a different configuration pin out relay is used. The modification entails soldering to the bottom of a socket which is then used in the holes for the original relay. However the traces on the bottom of the board also have to be cut and several patch wires are soldered in place. Unfortunately these wire paths now cross over one another when they should not. This reduces the performance of the front end because of cross modulation and signal leakage. I have photos of a board where this abomination was performed and a comparison board to show what the final product of that effort looks like in relation to the original design. If you are interested in those photos check my website at www.members.aol.com/NC4LMal . By the way if you have ever tried to solder a small wire to the underside of a small plastic socket with lead spacing of 0.1 inches, expect a lot of melted plastic and its fumes. You will need a very fine soldering pencil tip and very small gauge solder along with the vision of a preteen

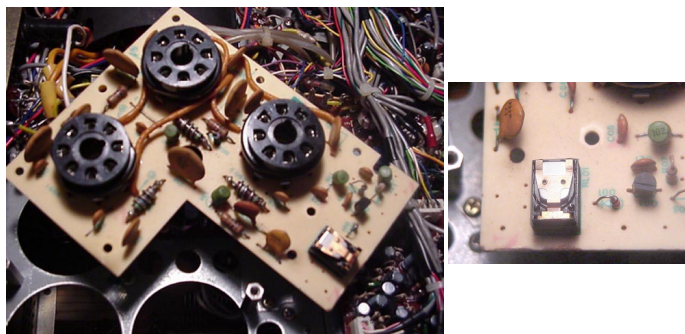

Final Board PB-2355 RL01 on the PA board

Another relay of interest in the FT-102 is RL01 on the final board PB-2355. See Photo to the left of the PA board, RL01 should drop the PA screen voltage from 210v to 180v when the transceiver is switched to the 10 meter band. The circuit on the final unit can be seen on page 63 of the FT-102 technical supplement in the lower right hand corner see L07, R06, Q01 transistor switch (2Sc1815) which then goes to the coil of RL01, ironically none of the parts listed here will show up on your schematic diagram. How is RL01 switched on and off? In the lower right hand corner of your final unit you will see a contact at L07 Labeled 28 Mhz. There is a brown wire on this corner of the board. That brown wire, if you're willing to take the time and trace the brown wire all the way back to the Local Unit PB-2345 its point of origin is tack soldered on to the Local unit at the Cathode end of D36 (It could be on D35/36/37/or/38) as all the cathodes of these diodes are tied together on the local unit. The other end of these diodes goes to P40/J01, which then goes to the band switch 10-meter positions

RL01 of the PA board should be bypassed, (Remove it!)

Yaesu initially placed it there to switch the screen voltage to a lower value when on ten meters for better efficiency. The relay was inconstant and gave them troubles so they just left it in the radio without switching it on or off. Since they didn't make the radio with RL01 active for regular production they took it out of the schematic so you will not see it although it is most certainly there. It was easier to erase the parts from the schematic than alter and redesign the boards. So just take the orange and white wire and place it on the other side of the relay so there can be no problems. RL01 on the RF / final unit makes no sense having it on the board, if you look at other transceivers like the FT-101ZD, FT-901/ 902 and possibly other transceivers that used the 6146 final manufactured by Yaesu, you won't find a relay like this.

I'm not sure what the Yaesu engineers had in their heads other then sushi and (Sake) rice wine on the day they all got together and designed this gem called the FT-102. But if we take a quick look at other transmitters using 6146 finals, you will see the screen voltage is usually well above the 210 used on all bands in the FT-102 (screen) Pin #3

Make	Rx	Tx Key Down
Yaesu FT-101ZD	220v	180v
Yaesu FT-901/902	264v	245v
Kenwood TS-820	255v	210v
Heathkit HW-101	300v	295v

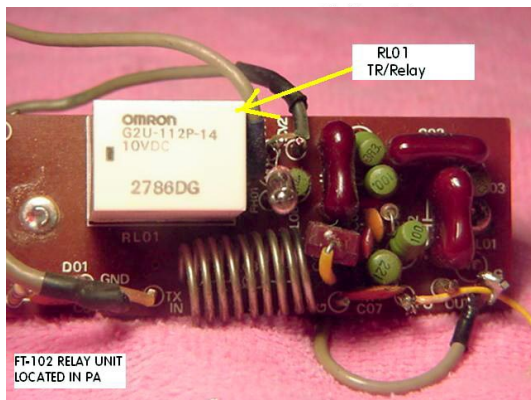
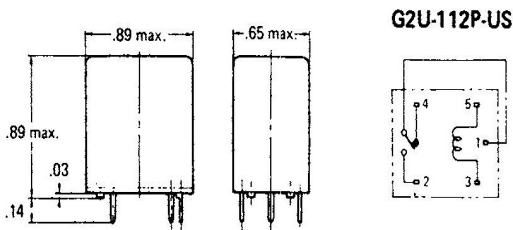

RL01 on PB-2355 of the FT-102 is for all practical purposes worthless, if it becomes intermittent or problematic just get rid of it or by pass it. I removed it from my transceiver and the rig is all the more reliable.

Relay Unit PB-2345, RL01 antenna T/R relay

Relay Unit PB-2345, antenna T/R relay, original RL01 on Relay Unit Omron was the G2U-112P/10V the relay has a coil rating of 5 to 24VDC according to the Last data sheet from Omron dated 1983 See: Omron G2U data sheet I recommend you download and save these data sheets because they will soon become lost in the archives of life never to be found again. I obtained these after many hours of searching and letter writing. The original G2U relay is a sugar cube-sized relay capable of switching 5A loads. Although no longer available as the G2U, other replacements are available such as the G8SN automotive relay OMRON G8SN-1C7-CUK/12 See: Omron G8SN data sheet the G8SN is not stocked by Omron's north American distributors, however it should be available in Europe.

Also see the G5LE See: Omron G5LE data sheet. This relay is often the cause of erratic Rx and Tx problems. If it becomes necessary to replace RL01 the T/R relay on PB-2345 on the antenna relay board it is recommended that you replace it with the more popular G5LE-14 that is more commonly stocked by Omron's north American distributors. The G5LE relay is a cubic, single-pole relay with contact ratings of 10 amps. First remove the two rear 6146 final amplifier tubes, loosen the back panel of the FT-102 so that it opens at the top, undo the SO239 ring then carefully rotate the relay board forward to get access to the solder side. Use solder wick to remove the old cube relay and replace it with the new G5LE-14. The relay has five contacts, it is a SPDT relay as it is either in receive or transmit mode.



Main Chassis Relays RL1 & RL2

RL1 & RL2 located on the main chassis of the FT-102 are both 4PDT relays. Nothing really special here, they are readily available from several sources and as an NTE replacement part. RL01 and RL02 are considered a general purpose 12 volt DC relay. You will see the following type relays used FRL263-DO12/04CS as well as Guardian Type 1315H (4PDT 5 AMP Contacts) Many sources are available for this type relay even Radio Shack carries a similar 4PDT relay. See: Specification sheet R12-17D3-12 or OMRON MY4-DC12 The large chassis relays RL01 and RL02 are infrequently a problem. They switch your 8, 12, and 15 volt lines as well as the AGC signal. Take them out and clean them by hand with a small relay burnishing tool. Put the tool between the contacts, and operate the switch or relay by hand to provide pressure on the contact while you move the burnishing tool in and out (like a file). The burnishing tool has a very very fine abrasive on it, so it only removes oxidation, not the metal. Then clean the contacts with Deoxit.

If you do not feel like cleaning the contacts then you can look for this relay using the following for reference.

NTE R12-17D3-12 Relay 4PDT contacts rated at 5A @ 240VAC. coil voltage is 12VDC. Terminals suitable for socket NTER95-117 Equiv. To Potter Brumfield KHU-17D12-12 & others like the Guardian #1314H and the Tyco PB KHU-17D12-12, 4-1393123-7



Main Chassis Relays RL1 & RL2
FRL263-DO12/04CS or
Guardian Type 1315H (4PDT 5 AMP Contacts)
Size: just over 1 cubic inch

Relay Unit PB-2345,

RL01 antenna 12 Vdc T/R relay

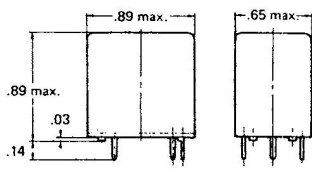

<http://www.foxtango.org>

G2U-112P-US

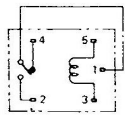

KHU-17D12-12-3

If you are looking for this relay check the following sources.

Ken's Electronics See Ken's Electronics R12-17D3-12 term 12VDC 5A104CMEWB, 104DO-12V, FRL263-DO12/04CS, KHU4D12, MAT4B/BR, MY4-DC12, Q22.1936, R14-12

Walco Industrial Electronics

Mouser.com

Original RL01 on Relay Unit:
Omron G2U-112P/10V

G5LE-14 Automotive relay available in USA

OMRON G8SN-IC7-CUK Automotive relay
(Europe only) not available in USA

Board	Qty
Relay unit PB-2345	1

FT-102 Main Chassis RL1 & RL2

Guardian Type 1315-H

4PDT 5 AMP Contacts

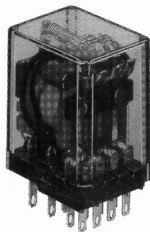

KHAU

Outline Dimensions

Mounting Code 1 - KHAU only.
2 & 4 Pole

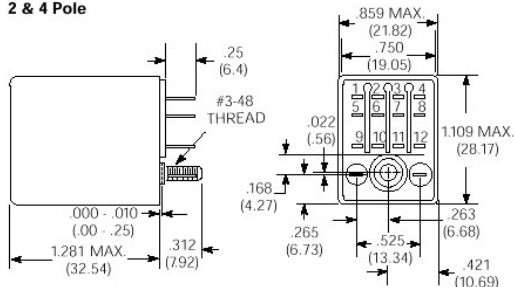

PC terminal models have rivet, not stud.
Max. seated height in 27E006 socket is 1.37" (34.8mm).

Wiring Diagrams (Bottom Views)

4 Pole

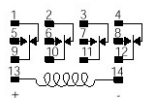

+ = Polarity for LED indicator.

Notes:

NOTE - NEVER USE A FILE TO CLEAN A RELAY CONTACT.
USE COARSE PAPER OR A RELAY BURNISHING TOOL.

If we have not provided you enough information on relays you might like to download the handy Relay Cross Reference Guide from Greenwich Electronics

Finally,

12v Vs. 24 volt relays on the FT-102 RF Unit. There is some controversy about this. NC4L Malcolm and I had several email exchanges about this and I agree with Mal on his thoughts regarding the Yaesu 24 volt relay modification for the RF Unit. My gut feeling on this is to remove the modification and leave the RF unit as it was from the factory.

This from Mal " My feeling is that it was used for a ballast for the front end supply. In other words instead of using the 12 volt supply for the relays - they found that the quality of the DC for the front end was better slightly loaded down. Remember the circuit for the 24 volts is not the most sophisticated or precision item as it is only zener regulated. They looked around and figured - lets power two relays with the front end supply so that the energy for the loading effect at least has a useful purpose. I am pretty sure that was the case as they certainly have an ample amount of 12 volt power to run the relays."

If you would like to see what it is we are talking about here, download and print out the following PDF for your files. See RF Unit 12volt Vs. 24volt relay modification RL04 and RL05

From: Harry Leeming (G3LLL) 3A Wilson Grove
Heysham Morecambe LA3 2PQ 0790 1932763 U.K.

The practical thing is that swapping relays on the RF board is hard work, and if you are going to exchange one, it is as well to swap the lot. The only other relay that gives a little trouble is the Ant change over, but swapping this is a separate job, it does not usually fail at the same time as those on the RF board. Life of relays on RF board is 3-5 years in a clean shack, less than 1 year with a heavy smoker

Installing those new relays in your FT-102

For those who have bought the FT-102 relay kits. Here are some hints to do the job. Please do not consider these to be step by step instructions, however my notes may help you do the job.

Basically replacing the FT-102 relays is not a difficult job to do except for one relay that sits under the band switch, RL05 on the RF Unit.

My advice on doing the job is TAKE YOUR TIME, DON'T be in a rush. Do the RL01 in the PA compartment one evening.

Loosen up the screws on the rear panel that hold the rear panel to the chassis. This will allow you to pull the panel out about 1/4 to 1/2 inch. This gives you some room. Needles to say remove all the covers for first, then the PA tubes and set them all aside. There is one yellow wire at the bottom of the Relay board if you want you can unsolder the yellow wire and this will allow you to pull the board up some so you can work on it, don't pull on the wires any more then you have to.

Replace RL01 T/R relay and then reverse the process. Take your time and only do that one relay part of the job then set it aside until you get the time to come back, don't try and do it all at once. Reassemble everything and test the rig after you change RL01 on the Relay unit (antenna T/R relay) test the rig and if all is a go, then take a break or proceed to the RF Unit.

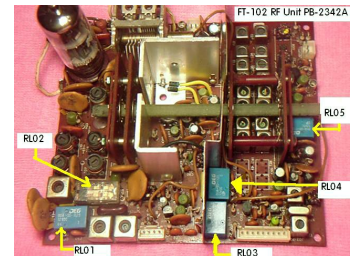
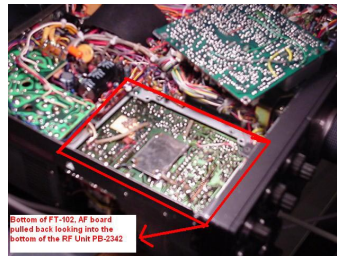
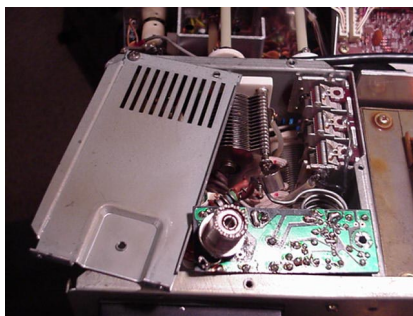
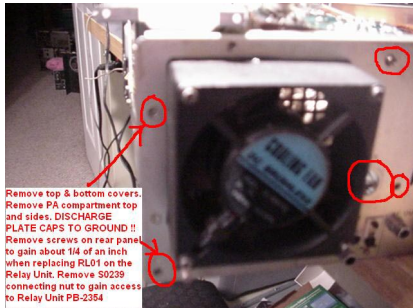

New Fujitsu RL02 Installed

RF Unit.... You get to the bottom of this board by carefully pulling the AF board back. I work with the rig flat on the desk and when I put in a relay, I held it in place with my finger, put a small piece of solder near the relay leg and tack solder one leg in first. Push up on the relay and then solder it again, then do the rest of the leads. DO NOT bend the relay legs to keep it in place. This will make it very difficult if you ever have to replace them down the line and will ruin the board if you have to take one out again some time in the future.

For more info on replacing FT-102 relays visit Jose's web page for how to do this as he has some good pictures on his site. http://www.jvgavila.com/ft102_1.htm

As for RL05 under the band switch. I've heard of different ways of getting this relay in and out. All agree that you have to unsolder each leg on the front two band wafers on the band switch. I personally don't mind doing a little extra work and taking my time doing so in order to do a job right. I disconnect the loading shaft and pulled it out, also disconnected the plate shaft and pulled it loose from the front. Then I removed the three screws on the front panel right side, this will allow you to pull the front of the radio forward about 1/4 to 1/2 of an inch. For the few extra minutes in doing this, it gives you a lot more room to work with from the front of the rig.

LET ME RECOMMEND ONE THING IF YOU PULL THE FRONT FORWARD...TAKE SOME KIND OF A MARKER, put the band switch straight up on 18 Mhz and mark the band switch before you pull the panel forward.

In case you have a brain fart and somehow the band switch moves, you will know where it goes back together. If you do it my way and pull the front panel forward a 1/4 to 1/2 inch BE DAMMED SURE YOU DO NOT LOOSE THE BLACK PLASTIC COUPLING FROM THE PART OF THE BAND SWITCH GOING TO THE MAIN SWITCH ON THE RF UNIT. Put all screws and parts in a container and don't lose them when you work.

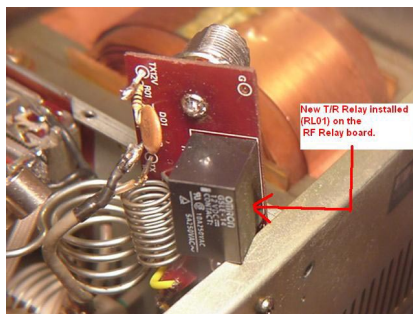
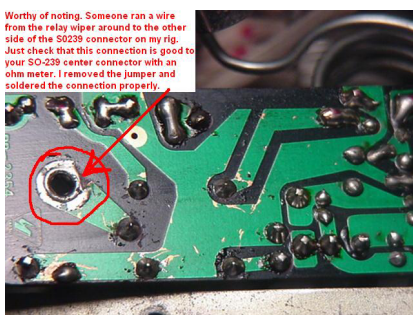
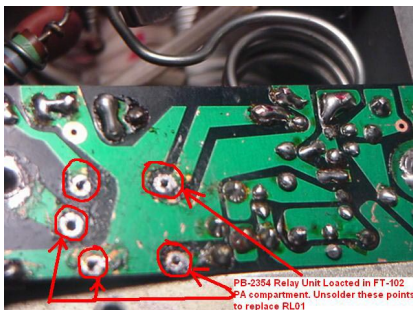

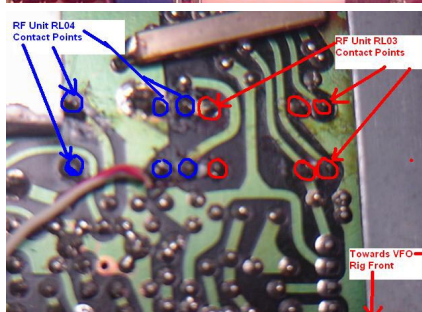
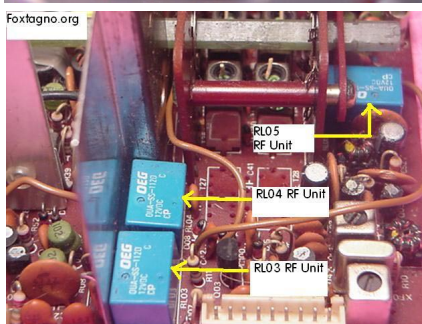
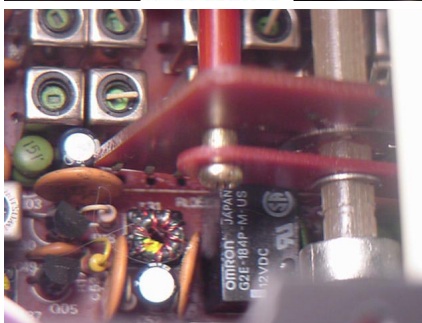
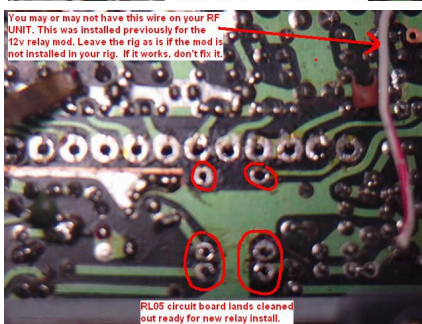
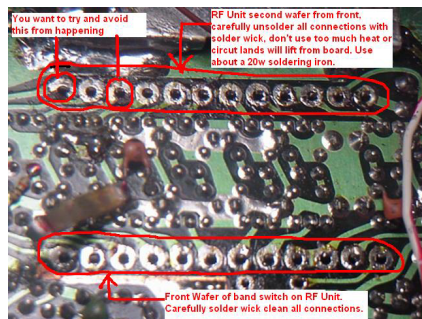
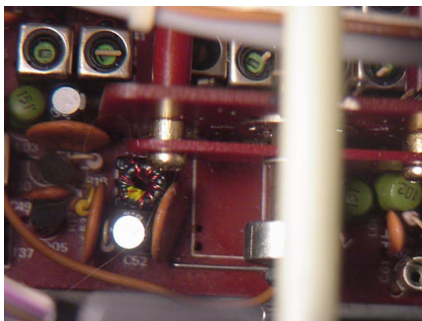

I talked to Malcom about this process for replacement of RL05. Mal said NOT to pull the panel. It's up to you. Mal told me that he unsolders the two wafers from the RF Unit and lifts up on the band switch wafers about a 1/4 of an inch and puts the relay on double sided stick tape attached to a pen or something. The he some how pushes it in. This may work for him but it's tight getting in to the front of the rig there with the front panel so close and you risk bending a pin on the small relay if it does not fit into the holes exactly right. So you have a choice, try Malcolm's way and maybe have to fight with it. Or pull the front my way and still fight with it, but hopefully less of a fight getting RL05 installed. Remember what I said in the second sentence at the top. TAKE YOUR TIME.

Most hams have more then one rig in the shack today, so don't get in a big rush to do this job.

New RL05 Installed

I was in no rush and even with pulling the front panel loose the whole process of replacing every relay on the RF Unit took me a little over an hour, maybe an hour and a half to do the entire RF Unit relay replacement job.

You can do it how you please, but I feel by pulling the loading shaft it allowed me to get my fingers into the area of RL01 / RL02 on the RF unit much more easily.

New RL03 and RL04 Installed

RL03 and RL04 are fairly straight forward and easily enough to replace. Make sure when removing the old relays your soldering iron is hot enough to melt the solder but not so dammed hot you destroy the circuit board traces when removing the relays.

Use SOLDER WICK to suck up the excess solder. DO NOT USE A SOLDER SUCKER. When the relay is out use the solder wick again to make sure the hole is completely clean before attempting to put in the new relay in place.

By the time you get this far, you have completed the hard part and will have installed six out of eight relays included in the Fox Tango relay package.

FT-102 IF Unit FT-102 Control Unit

You will install one more small Omron relay on the FT-102 I.F. Unit and one on the Control unit. Since there is only one relay on each of these boards, this should be pretty much self explanatory. After replacing these relays you are finished with the relay modification for you rig, with the one exception noted below.

The FT-102 has one more relay on the RF Unit. This is the board that resides directly under the final amplifier tubes and houses the three tube sockets.

We did not include this relay in the kit. The reason for this is the best thing to do if this relay becomes intermittent is just to remove it.

Final Unit, PB-2355 why remove RL01?

Here is a little more info on RL01 on the Final Unit (The board with the 3 tube sockets) RL01 should drop the screen voltage from 210v to 160v when the transceiver is switched to 10m. The circuit on the Final Unit can bee see on page 63 of the technical supplement in the lower right hand corner see L07, R06, Q01 transistor switch (2Sc1815) which then goes to the coil of RL01. How is this supposed to be done? In the lower right hand corner of the Final Unit you see a contact at L07 Labeled 28 Mhz. There is a brown wire on this corner of the board. That brown wire if you're willing to take the time and trace it back goes all the way back to the Local Unit PB-2345. How do I know, I followed it back. It's tack soldered on to the Local unit at the Cathode end of D36 (It could be on D35/36/37/or/38) as all the cathodes of these diodes are tied together on the local unit. The other end of these diodes goes to P40/J01, which then goes to the band switch 10-meter positions.

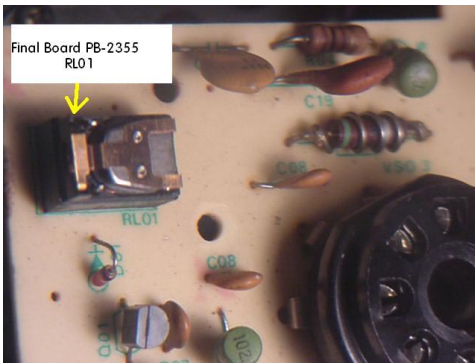

RL01 of the PA board should be bypassed. Yaesu initially placed it there to switch the screen voltage to a lower value when on ten meters for better efficiency. The relay was inconstant and gave them troubles so they just left it in the radio without switching it on or off. Since they didn't make the radio with RL01 active for regular production they took it out of the schematic so you will not see it although it is most certainly there. It was easier to erase it from the schematic than alter and redesign the boards. So just take the orange and white wire and place it on the other side of the relay so there can be no problems.



Finally One last thing regarding that 12v / 24v relay modification on the RF Unit. If you would like to see what it is we are talking about here, download and print out the following PDF for your files. See RF Unit 12volt Vs. 24volt relay modification RL04 and RL05

Our suggestion to you regarding this modification is if what you have now installed in the rig is working leave it alone, if it works don't fix it.

I hope this helps you out a bit.
 If you have any problems please feel free to drop me a note.
 73
 Carol W4CLM



Join us at Fox Tango International ! <http://foxtango.org>

Fox-Tango International is a club where all users of Yaesu equipment find equally minded hams who help each other to keep their older and newer Yaesu equipment in excellent condition. In our forums we discuss all kinds of problems that arise and ways to solve problems and find solutions for hard to get spareparts and much, much more.

Please visit our website and see for yourself

The membership is free of charge, so join us to keep your Fox Tangos on the air !!

FT-102 Manuals

You can download the FT-102 User and Service Manual direct from the Fox-Tango FT-102 site at: <http://foxtango.org/FT-102/FT-102%20Page.htm> or from: Kevin Withemarsh YAESU manual site, where you will find almost every YAESU manual that you may need. His library website is on: <http://foxtango.ham-radio-op.net/>

Take note: for some of the bigger sized manuals is it necessary that you join the Fox Tango International club, because downloading of them is restricted to members.

Yaesu FT-102 troubleshooting hints

by Carol Maher W4 CLM

RF AMP NOT WORKING : If your RF amplifier is inoperative, turn the volume all the way down on your transceiver, push the RF Amp button thus checking the Relay and control circuit. You should be able to hear the RF Amp relay click on and off with the button. If after checking the relay your amp is not working it can be assumed re-amp transistors Q01 and Q02 on the RF Unit. FETS on the RF unit (2SK125) could very well be bad. Data sheet for Sony 2SK125 This was a common failure item on the FT-102. HTML page 2SK125 data sheet below.

LOW RX SENSITIVITY : Check antenna input lamp fuse which is a small lamp fuse located on the relay unit in the PA compartment. It is not possible to use any old bulb here as some bulbs may cause several dB attenuation. Recommend replacing the lamp fuse with original equipment

INTERMITTENT LOW RX SENSITIVITY : Suspect the relays on the RF pcb around the RF amp. Don't miss RL04 this is the relay at the front of the board under the shaft of the band switch which is difficult to change. Cleaning the relays can help but they usually go intermittent again within a few weeks - it's better to replace them if they are available.

PRESELECTOR NOT TUNING CORRECTLY : There is a shaft coupler on the band switch shaft - if the screws in this are loose it is possible for the front and rear sections of this switch to be out of physical alignment.

NO RF OUTPUT (PA DRAWING CURRENT AS NORMAL) : The main antenna T/R relay has been known to burn its contacts. .

PA FAULT CONDITIONS:, Rig blowing fuses : Check for physical short circuits around the band switch in the PA compartment. Inspect the rear panel fuse socket and see if the (+) slot for a screw driver is worn down. If so this is a good indication that the rig has been blowing fuses thus you possibly have one or more 6146 final amplifier tubes that are failing or arcing occasionally.

ERRATIC CONDITION WHEN LOADING CONTROL IS VARIED, especially below setting of 2 on panel marking. Varies smoothly when top of final amplifier compartment is removed. Trouble returns when PA top cover replaced. The loading capacitor frame touches the top cover of compartment. Insulate top cover around loading control.

FLUCTUATING POWER OUTPUT : check 6146 finals for arcing, check PA (RFC) choke.

FT-102 POOR AUDIO WHEN USING LINEAR: Many complaints about poor audio have been received when using a linear amplifier that were traced to RF entering the 102 through a connected phone patch. Since most people don't use phone patches anymore, the simple fix is just to remove it. the demise of phone patching has all be resulted due to cellular phones and Email. If you're so inclined to fix the problem properly a little effective filtering to prevent the entrance of RF through accessories should take care of the problem.

REMOVE CB MODIFICATIONS: See: Yaesu mod sheet and reverse all mods. The CB modification allowed the 29-30Mhz range to cover 27-28Mhz and the counter also had to be modified to display CB frequencies, so it will have to be re-worked as well.

NO TX : Check the series pass transistor in the 12v. regulator circuit.

NO TX - NO DRIVE : R01 on RECT A UNIT. Check driver valve after replacing this.

POOR NEUTRALIZATION : This can sometimes be a problem if 2 or 3 different types of valves are used in the PA.

PA WON'T NEUTRALIZE : PA screen grid supply to a higher voltage on the rectifier unit, causing this problem.

FREQUENCY SHIFTS WHEN CLARIFIER ON : Dirty contact on RL4001, the clarifier relay.

FM TX WAY OFF FREQUENCY : Failure of Q13 (TC5081P) on AM/FM unit. See Yaesu mod sheet to prevent further failure.

LUMPY VFO DRIVE : Improved can be had by cleaning and re-lubrication of the the tuning mechanism. If its really bad the drive will probably need to be replaced.

KEY CLICKS : Some of the earlier models suffered from key clicks on CW. To cure this connect a 0.68 microfarad cap between key 1 on the REC A board and earth.

DRIFT ON CW : Some of the early units suffered from a drift of 50-100Hz during the first couple of minutes of CW transmission. Yaesu suggest removing C153 (3.3 microfarad) on the local unit to cure this problem. It is located between X4002 and T4014.

onliner: If all else fails, read the destructions

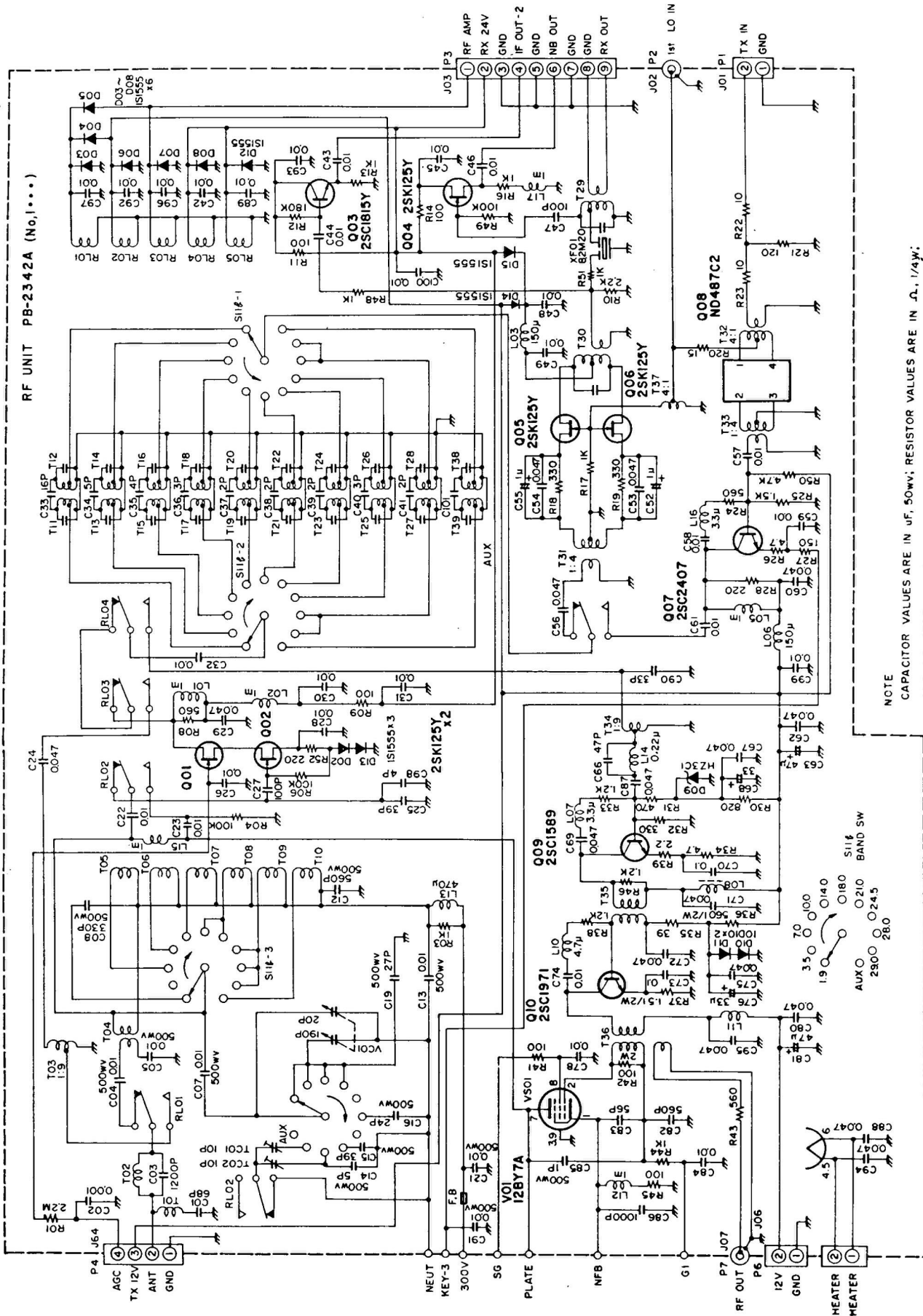

NOTE
 CAPACITOR VALUES ARE IN μ F, 50WV; RESISTOR VALUES ARE IN Ω , 1/4W,
 AND INDUCTOR VALUES ARE IN HENRIES UNLESS OTHERWISE NOTED.

FT-102 RF board, schematic diagram

FT-102 Circuit boards and circuit descriptions

by Carol Maher W4CLM and Wim Penders PA0PGA

PB-2342A, RF Unit

Receiver:

The incoming signal from pin 2 of J-1004 is fed through RL-1001 (RF amplifier on/off relay) to the preselector circuit selected by the bandswitch. Then the signal goes through T/R relay RL-1002 to the gate of the RF amplifier Q-1002. AGC is applied to the gate of Q-1001 and Q-1002 (2SK125Y) are together used as a RF amplifier, in a dual gate Fet arrangement, (not unlike a cascode VHF amplifier in earlier days). It combines low-noise amplification with large signal handling.

The signal is then fed through the RF amplifier relay RL-1003 and T/R relay RL-1004 to one of the bandpass filters, selected by two sections of the bandswitch.

When the RF amplifier is switched off, the signal is passed directly from RL-1001 to RL-1003, and to the bandpass filter, bypassing the RF amplifier and giving a still better great signal handling.

From the bandpass filter the signal is fed through the T/R relay RL-1005 and transformer T-1031 to the active balanced mixer, Q-1005 and Q-1006 (2SK125Y). Here the signal is mixed with the first LO signal from the Local Unit.

The resulting 8.2 Mhz mixer product is then passed through transformer T-1030 and XF-1001, a monolithic crystal filter with a bandwidth of 20 khz (a kind of roofing filter to remove IMD causing products), and transformer T-1029 to the IF Unit.

A sample of the wideband IF signal at T-1030 is buffered by Q-1003 (2SC1815Y) for external monitoring, via the IF-Out-2 jack. A sample of the filtered IF signal at T-1029 is buffered by Q-1004 (2SK125Y) for delivery to the noise blanker circuit on the IF Unit and the FM receiver circuit in the optional AM/FM unit. The transistors Q-1001 through Q-1006 operate all from the 24Vdc supply, used to obtain a very good large-signal handling.

Transmitter:

The modulated and filtered 8.2Mhz IF signal is applied to the balanced mixer module Q-1008 (ND487C2 schottky bridge), along with the first LO signal from the Local Unit, resulting in an output signal at the operating frequency. This signal is amplified by Q-1007 (2SC2407), Q-1009 (2SC1589) and Q-1010 (2SC1971) before application to the driver tube V-1001 (12BY7A).

A sample of the input to the driver is fed to the RF-Out jack on the rear panel, for use with a transverter.

Output from V-1001 (12BY7A) is resonated by the preselector on the band, selected by the band switch, and then delivered to the Final Unit.

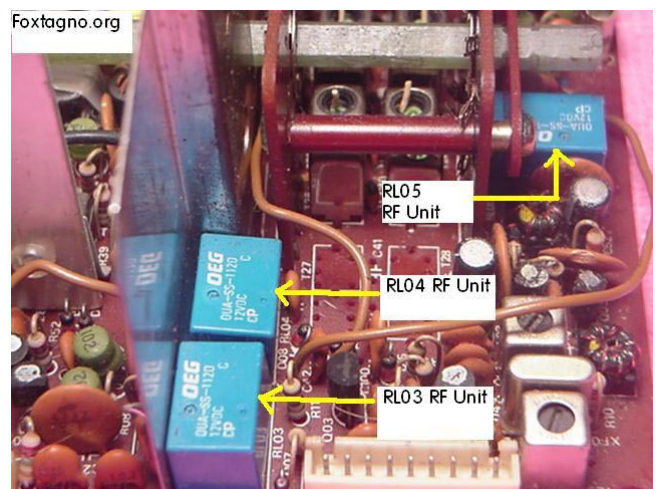
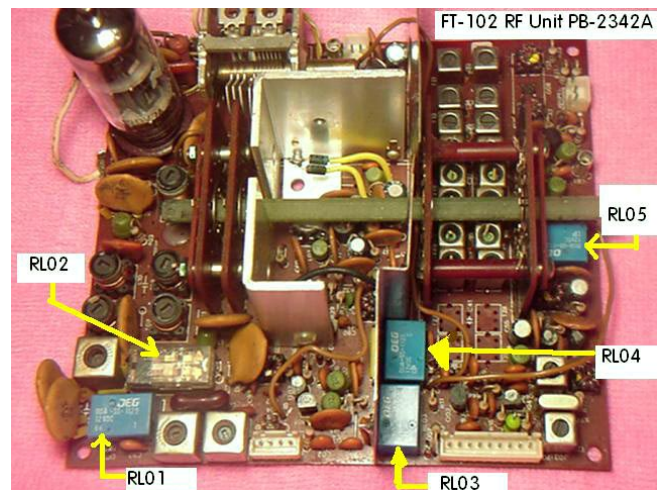

PB-2355 Final Unit

On the Final Unit the transmit signal is brought up to full power at V-9801 to V-9803 (6146B) before delivery through the final tank circuit on the main chassis to the Relay Unit. (PB2354)

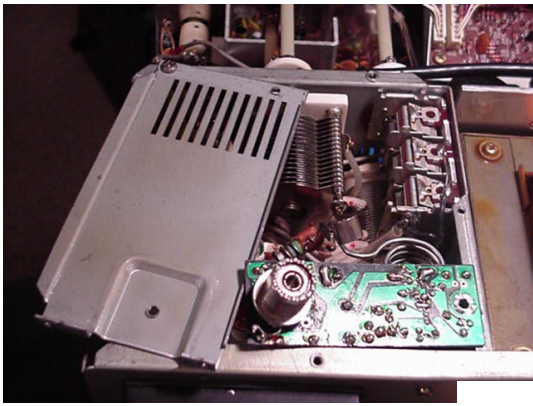

PB-2354 RELAY Unit

On the Relay Unit the signal is fed through T/R relay RL-9601 to the coaxial ANT jack, with a sample delivered through the PO ADJ potentiometer on the rear panel and the METER SELECT switch to METER I

PB-2343A, IF Unit

Receiver:

The 8.2 Mhz signal from the RF unit is amplified by the first IF amplifiers Q-2001 and Q-2002 (2SK125Y), which are also operated from the 24V supply to maintain excellent large signal performance. The amplified first IF signal is then passed through the noise gate, composed of two schottky diodes D-2001, D-2002 (1SS97) and a varactor diode D-2003 (FC63) before being applied to the first set of crystal filters.

SSB and CW signals are passed through a 2.9 khz wide 8-pole crystal filter XF-2001 (**XF-8.2HS**), while AM signals are passed through a optional 6 khz wide, 3-pole monolithic ceramic filter XF-2002 (**XF-8.2GA**). If XF-2002 is not installed, AM signals pass through XF-2001.

When the NAR button is pressed on the front panel, CW signals are passed through one of the optional narrow second filters in location XF-2003: this can be either the 600hz width, 8-pole crystal filter **XF-8.2HC**, or the narrower 300hz width, 8-pole crystal filter **XF-8.2HCN**. When the NAR button is pressed in the SSB mode, the SSB signals are passed through one of the optional narrow SSB filters in location XF-2004, this can be the optional 2.9khz wide 8-pole crystal filter **XF-8.2HS**, or the narrower 1.8khz wide, 8-pole crystal filter **XF-8.2HSN**.

All signals from XF-2001, (and AM signals from XF-2002, if installed) are delivered to the second IF amplifier Q-2003 (3SK73GR) when the NAR button is off, or the optional filters are not installed; otherwise CW and SSB narrow signals from the second filters are applied to Q-2003 after narrow filtering. After amplification, the filtered 8.2khz IF signal is applied to the second mixer Q-2004 (3SK73GR) where it is heterodyned with the 8.67 Mhz second LO signal from the Local Unit, producing the 455 khz second IF.

CW and SSB signals are then filtered by a third filter CF-2001, a 2.9 khz width, 3-pole ceramic filter (**CMF455J1**); unless optional CW-narrow third filters are installed at XF-2005 (either a 500hz 8-pole filter **XF-455C** or a 270hz, 8-pole filter **XF-455CN**) and the

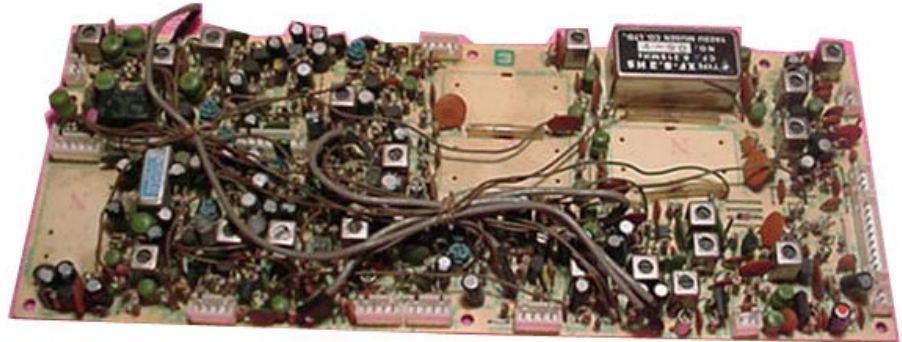

NAR button in pressed.

AM signals bypass these filters.

All signals are fed from the third filter bank through the Q-Multiplier, composed of Q-2006 and Q-2007 (2SC1815Y) and notch filter Q-2008 (2SC1815Y) to the 455khz IF amplifier Q-2010 (3SK73GR).

A portion of the amplified signal is then amplified by Q-2011 (2SC1815Y) and fed to the Narrow-Band IF-Out-1 jack, the AM detectors D-2038 and D-2080 (1N60) and the AGC detectors D-2039 and D-2040 (both 1N270). The remainder of the amplified signal from Q-2010 is delivered to the product detector on the AF Unit. The detected AM signal from D-2038 is delivered to the AF Unit for filtering and amplification. The detected AGC signal from D-2039 is amplified by Q-2012 (2SC1815GR), and a portion of of the output is fed back to the IF amplifier Q-1001 for gain control, while another portion is further amplified by the S-meter amplifiers Q-2013 (2SK19TMGR) and Q-2014 (2SA564AR) before delivery through T/R relay RL-2001 to meter II.

Noise Blanker:

Buffered output from the 20 khz filter XF-1001 is amplified by Q-2019 and Q-2020 ((2SC1583) as well by Q-2021 (2SC380TMY) before being applied to noise detectors D-2053 and D-2054 (1N60).

A portion of the output from Q-2021 is also rectified by D-2055 and D-2056 (1N60) and amplified at Q-2022 (2SC1815GR) for feedback to Q-2019 and Q-2020 as noise blanker AGC. The time constant of this AGC is adjusted by the NB LEVEL control on the front panel.

Output from the noise detector is buffered by gate control Q-2018 (2SC1815GR) before being applied to the noise gate D-2001-D-2003 who are located between the first IF amplifier and the first bank of crystal filters.

Transmitter:

The double sideband modulated signal from the AF Unit is buffered by Q-2005 (2SK19TMGR) and passed through ceramic SSB filter CF-2001 to mixer Q-2017 (3SK73GR), unless the speech processor is on, in which case the filtered remaining sideband from CF-2001 is amplified by second IF amplifier Q-2017 (also used in the receive path) and Q-2015 (2SC1815Y), a portion of the output of which is diverted to amplifier Q-2023 (2SC1815GR) for COMP indication on meter I. The remainder of the output from Q-2015 is clipped by limiter-amplifier Q-2016 (TA7060P) before being applied to mixer Q-2017 (3SK73GR).

The 8.7 Mhz second LO signal from the Local unit is mixed with the modulated 455khz signal at Q-2017 to produce an 8.2Mhz IF, which is then filtered through XF-2001 in the first bank of filters and amplified by Q-2003 (also used in receive) before delivery to the RF unit.

Monitor:

A portion of the output of IF amplifier Q-2003 is buffered by Q-2024 (2SC380TMY) and fed to the transmit monitor mixer Q-2025 (2SK19TMY), which is also fed the second LO signal from the Local Unit. The 455khz output of Q-2025 is then demodulated at Q-2026 ((2SK19TMY), which is also fed a portion of the third LO signal from the Local Unit after buffering at Q-3017 on the AF Unit. The resulting audio signal from Q-2026 (2SK19TMY) is amplified by Q-2028 (2SC380TMY), which also amplifies a sample of the audio input from the FM detector Q-6008, delivered from the optional AM/FM Unit, when the FM mode is used, as well amplifies the output from the monitor AM detector Q-2027 (2SC380TMY), which receives IF output from Q-2024. The output of amplifier Q-2028 is delivered to the final audio amplifier Q-3025 on the AF Unit for output to the speaker or headphones.

PB-2344: AF Unit

Receive:

The SSB or CW 455khz IF signal is detected at D3021-D3024 (1N60), which also receives the 455khz third LO signal from the Local Unit, after buffering at Q-3018 ((2SC1815Y).

The CW audio product is then passed through an active CW filter, Q-3020 ((2SC1815GR) and APF filter Q-3024 (AN6551); while the SSB audio product and the detected AM are passed through active filter Q-3022 (2SC1815GR) and amplifier Q-3023 (2SC1815GR); after which each signal is applied to analog switch Q-3019 (MC14066B), which selects the appropriate mode via the MODE selector for further amplification. Finally, the selected output is fed through the muting switch Q-3030 (2SC1815Y) to the audio power amplifier Q-3025 (uPC2002V) and from there to the speaker. A portion of the output signal from Q-3019 is diverted through amplifier Q-3016 for auxiliary output at the AF-OUT jack on the rear panel.

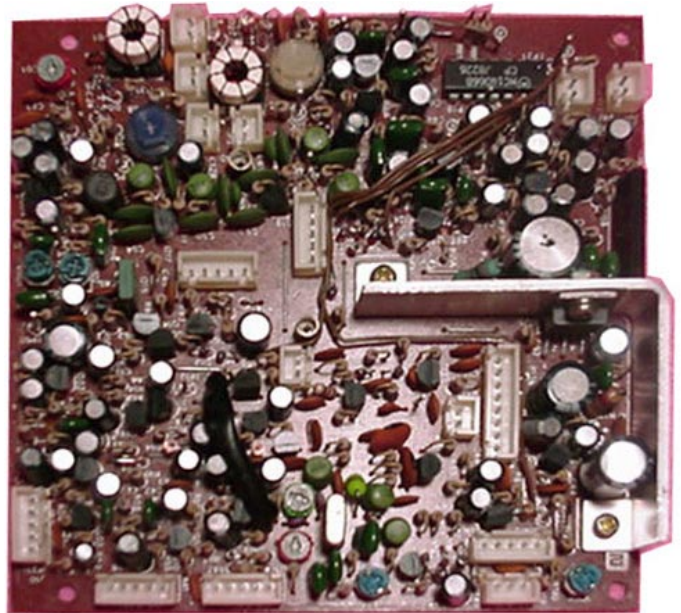

Transmit: SSB Mode

The speech signal from the microphone jack is amplified by Q-3001 (2SC732TMGR) and Q-3002 (2SC1815Y). A portion of the speech signal is diverted for VOX operation. The remaining signal from Q-3002 is further amplified by Q-3003 (2SC1815BL) and passed through adjustable TX tone filters to tone amplifier Q-3004 (2SC732TMGR). A portion of the output from Q-3004 is diverted to the optional AM/FM Unit, when installed; while the remainder is applied to the balanced ring modulator, composed of Schottky diodes D-3002 to D-3005 (1SS97)

The balanced modulator receives also a 455khz LO signal from the Local Unit after buffering by Q-3017 ((2SC1815Y), and the resulting modulated IF is delivered to the IF unit.

VOX, Anti-Trip

A portion of the amplified speech signal from Q-3002 is amplified for VOX operation by Q-3010 (2SC1815Y), and then rectified by D-3014 (1N60) to produce a DC voltage, whose level varies with the speech input at the microphone. This DC is amplified at Q-3011 (2SC1815Y), and further amplified at Q-3012 (2SC1815Y) before being applied to switch Q-3009 (2SA733). The switched output of Q-3009 then controls a Schmitt trigger composed of Q-3013 and Q-3014 (2SC1815Y), which in turn switches relay control Q-3015 (2SA496Y) to drive T/R relays RL1 and RL2 on the main chassis.

The anti-trip signal is derived from a sample of the output from audio amplifier Q-3025, or from an external source via the A-TRIP IN jack on the rear panel.

This signal is amplified by Q-3006 (2SC1815Y) and then rectified by D-3011 to produce a DC voltage whose level varies with the audio output from the receiver. This DC is amplified by Q-3007 (2SC1815Y) and Q-3008 (2SA733) before being fed into the VOX control circuit at Q-3012, to counter the VOX DC voltage that is produced by audio at the microphone.

CW Mode

The CW carrier is generated by crystal oscillator Q-3026 (2SK19TMGR), activated by analog switch Q-3019 in the CW, AM and FM modes through Q-3029 (2SC380TMY) and applied through amplifier Q-2003 on the IF Unit to balanced mixer Q-1008 on the RF Unit as for SSB operation. Final amplification is the same.

The key lead from the key jack activates sidetone oscillator Q-3005 on the AF Unit and also controls switches Q-8001 (2SA639Q), Q-8002 (2SC1815Y) and Q-8003 (2SA639Q) to turn the biases to the final tubes on and off. Q-8002 also keys post TX mixer amplifier Q-3026 and offers a keyed control point at pin 2 of the ACC-1 jack. The sidetone oscillator provides an output to VOX amplifier Q-3010 to activate the VOX circuit for semi break-in CW control.

PB-2347 Optional AM/FM Unit.

FM Receive

A portion of the buffered IF signal (after the 20kHz filter XF-1001) from Q-1004 is delivered through another 20kHz width filter XF-6001 on the AM/FM Unit to the mixer section of Q-6008 (MC3359), which also contains limiter-amplifier, discriminator, noise amplifier and AFC sections.

In the mixer section the filtered receiver IF is mixed with the 8.67 Mhz second LO signal delivered from the Local Unit, resulting in a 455kHz second IF. This signal is passed through ceramic filter CF-6001 and fed to the IF limiter amplifier section of Q-6008, where amplitude variations are removed from the signal. The signal is then applied to the discriminator section of Q-6008, resulting in an audio output coinciding with frequency shift in the 455kHz IF signal.

When no carrier is present in the 455kHz IF, the high frequency noise present at the discriminator output is amplified by the noise amplifier section of Q-6008 and rectified by noise detector D-6004 (1N60). The resulting DC voltage is passed through the SQL control back to Q-6008 which turns off the audio output when no carrier is present.

When a signal is received the audio output from Q-6008 is delivered to audio amplifier Q-3025 on the AF Unit unless the MUTE line grounded, in which case Q-6012 (2SC1815GR) grounds the output signal from Q-6008. AFC output from Q-6008 is filtered and delivered through the METER I for discriminator tuning indication.

FM transmit

The signal from tone amplifier Q-3004 on the AF Unit is also delivered to limiter amplifier Q-6014 (uPC577H) on the AM/FM Unit, where the audio signal amplitude is amplified and limited to a preset level, preventing over-deviation. This signal is then applied to varactor diode pair D-6003 (MV104) to phase modulate 8.2 Mhz VCO (voltage controlled oscillator) Q-6006 (2SK19BL) serving as part of a PLL (Phase Locked Loop). One portion of the VCO output is buffered by Q-6004 (2SK19TMGR) and then divided by 256 at Q-6005 (TC5082P) for application to phase detector Q-6013 (TC5081P).

Carrier oscillator Q-3026 on the AF Unit delivers its signal, after buffering by Q-3029 to buffer Q-6002 (2SK19TMGR) which signal is then divided by 256 at Q-6003 (TC5082P) and applied to phase detector Q-6013 along with the signal from Q-6005. Q-6013 then presents a DC output voltage proportional to the phase difference between the divided carrier signal and the divided VCO signal, which is passed through active filter Q-6015 (2SC1815GR) back to modulator varactor D-6003, thus locking the VCO frequency to that of the carrier oscillator. The remainder of the frequency modulated signal from VCO Q-6006 is buffered by Q-6007 (2SC380TMY) and delivered through IF amplifier Q-2003 on the IF Unit to the second transmit mixer Q-1008 on the RF Unit. A sample of the buffered VCO output from Q-6006 is also delivered to the input of FM receive detector Q-6008 for IF monitoring of transmitted signals.

AM transmit:

A portion of the amplified and filtered speech audio from the tone amplifier Q-3004 on the AF Unit is delivered to AM modulator Q-6001 (TA7069P) on the AM/FM Unit, which also receives a carrier signal from carrier oscillator Q-3026, buffered by Q-3029 (2SC380Y), also on the AF Unit.

The modulated AM output is then delivered through IF amplifier Q-2003 on the IF Unit to the final transmit mixer Q-1008 on the RF Unit, as for SSB and CW, and final amplification is the same.



PB-2345 LOCAL UNIT

Bandswitching signals from the BAND selector are delivered through the Counter Unit to J-4001 on the Local Unit, selecting one of the six VCO's Q-4001 – Q-4006 (2SC945Q) for the band of operation. The selected VCO oscillates at the first LO frequency, and provides output through buffer Q-4007 (2SC535B) to buffer Q-4008 (2SC2407), which is also controlled by the unlock signal.

Q-4008 provides first LO output at J4002 for delivery to the RF Unit.

A portion of the VCO signal is buffered by Q-4011 (2SC535B) and applied to PLL mixer Q-4012 (SN76514), which also receives a 13.715 to 34.215 Mhz PLL Local signal from buffer Q-4013 (2SC535B), whose frequency is determined by the band, mode, IF shift and VFO setting for the operating frequency. The 1.0 to 4.0 Mhz

output from PLL mixer Q-4012 is then passed through a bandpass filter and buffered by Q-4014 and Q-4015 (2SC535B), before being fed to programmable divider Q-4017 (74LS192). Q-4017 is programmed by bandswitching signals to provide a output of 500 khz, regardless of the operating frequency. This output is applied to phase detector Q-4018 (MC4044) which also receives a 500 khz reference signal derived from 10 Mhz crystal oscillator Q-4026 (2SC945Q), buffered first by Q-4028 (2SC945Q) and then divided by 10 at Q-4019 (74LS90) and again by 2 at Q-4020(MC14518) before final buffering at Q-4021 (2SC945Q).

Q-4018 provides a DC output, proportionally to the phase difference between the VCO derived input and the reference derived input. The Dc output is then delivered through active low-pass filters Q-4022 and Q-4023 (2SC732GR) to the varactor of the selected VCO, thus locking the VCO frequency to the reference oscillator. If the output from phase detector Q-4018 is too great to allow locking of the VCO, an unlock signal is delivered through amplifier Q-4016 (2SA733) to the unlock switch Q-4009 (2SC945Q) which disables first LO buffer Q-4008, removing the first LO signal from the RF unit. A portion of the switching signal from Q-4009 also switches Q-4010 (2SC945Q) which delivers a blinking command signal to the Counter Unit, causing the display to blink whenever the PLL is unlocked.

The PLL local signal is derived from a 10 Mhz reference oscillator Q-4026 and 19,21 Mhz VCXO Q-4033 (2SC945Q) along with the VFO input. Output from VCXO Q-4033, shifted appropriately for the selected operating mode by Q-4032 (2SC940Q) and according the IF shift function, is buffered by Q-4035 (2SC945Q) and applied to PLL local first pre-mixer Q-4024 (SN76514), which also receives a 5.0 to 5.5 Mhz signal delivered from the VFO Unit or external VFO jack, through a low-pass filter.

The 13.715 to 14.215 Mhz output from pre-mixer Q-4024 is then filtered through a bandpass filter composed of T-4001 through T-4003 before being delivered to the PLL mixer (for the bands below 14 Mhz).

For operating on the bands above and including the 14 Mhz band; the 13.715 to 14.25 Mhz filtered signal is applied to PLL local second pre-mixer Q-4025 (3SK73GR), which also receives a 10 Mhz signal, filtered through bandpass filter T-4011 (for operating frequencies between 14 and 21 Mhz), or a 20 Mhz signal from times 2 multiplier Q-4029 (2SC945Q) for operating frequencies on or above 21 Mhz.

Both the 10 and 20 Mhz signals are derived from 10 Mhz crystal oscillator Q-4026, through buffer Q-4027 (2SC945Q). The output from the second pre-mixer Q-4027 is then passed through one or two bandpass filter networks, composed of T-4004 through T-4006 or T-4007 and T-4008 for the 14 and 18; or 21, 24.5 and 28 Mhz bands respectively.

The filtered output from the appropriate bandpass filter is then buffered through Q-4013 and applied to the PLL mixer Q-4012 as before. Frequency and filter selection is made through diode switches by commands from the BAND selector.

The 8.67 Mhz second LO signal is derived from the 19.215 Mhz VCXO and the signal from another 10.54 Mhz VCXO (actually 10.5466 for USB, 10.5434 for LSB, and 10.545 Mhz for AM); with continuous frequency adjustment by the Width system. The output of this 10.54 VCXO Q-410.54 VCXO Q-4036 (2SC945Q) is buffered by Q-4037 (2SC945Q) and applied to second mixer Q-4038 (3SK73GR) which also receives a signal from 19.215 Mhz VCXO Q-4033 after buffering by Q-4034 (2SC945A). The 8.67 Mhz output from mixer Q-4038 is then buffered by Q-4039 (2SC945Q) and passed through a bandpass filter for delivery to the IF Unit from J-4008 and to the AM/FM Unit from J-4009.

The 455khz third LO signal is derived from 10 Mhz reference oscillator Q-4026 and 10.54 Mhz VCXO Q-4036. The 10 Mhz signal, after buffering by Q-4028 and division by 10 at Q-4019 (see PLL description) has its 1 Mhz square pulse signal filtered through a bandpass filter composed of T-4012 and T-4016, to provide an 11 Mhz signal for third LO mixer Q-4040 (3SK73GR). Q-4040 also receives a portion of the buffered 10.54 Mhz signal from Q-4037, thus providing an output at 455 Khz, buffered by Q-4041 (2SC945Q) and passed through a lowpass filter for delivery from J-4011 to the AF Unit. This unique frequency derivation scheme allows the shift function to tune the second LO at 19.215 Mhz VCXO Q-4033, while the width function synchronously tunes the second LO and third LO, commonly derived from 10.54 VCXO Q-4036.

Sample data to the Counter Unit for frequency display is derived from both the VFO signal and the 10 Mhz reference oscillator Q-4026. Reference divider Q-4019 provides a 2 Mhz square pulse for this purpose, which is filtered at T-4013 to provide a 6 Mhz signal to counter sample mixer Q-4030 (3SK73GR), which also receives the VFO signal after lowpass filtering. The resulting 0.5 to 1.0 Mhz mixer product is passed through another lowpass filter before delivery from pin1 of J-4013 to the Counter Unit.

A clock signal for the Counter Unit is also derived from 10 Mhz reference oscillator Q-4026 after division by 10 at Q-4019, further division by 40 and Q-4020 (see PLL description), buffering by Q-4031 (2SC945Q) and lowpass filtering. This 25 khz signal is brought out for the Counter Unit at J-4013, pin 3, while a portion of the unfiltered signal is delivered from J-4014 to the receiver input at the EXT ANT jack on the rear panel, providing a MARK signal for the receiver, when the MARK button is depressed.

Second reference divider Q-4020 also provides a 100 Khz signal, delivered from J-4015 to the EXT VFO jack and the ACC-1 receptacle on the rear panel.

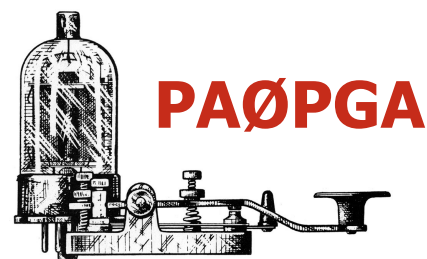



PB-2348 VFO UNIT

Variable frequency Oscillator module Q-7001 (VFO-1) provides an output of approx. 4.95 to 5.55 Mhz, in accordance with the setting of tuning variable capacitor VC-7001; paralleled with temperature compensating capacitors and trimmers and Clarifier varactor D-7001 (1S2236), whose capacitance is varied by changes in the clarifier control adjusted from the CLAR control, when the CLAR function is activated on either transmit or receive. Output from Q-7001 is fed through a bandpass filter before delivery from pin 1 of J-7001 to the local unit.

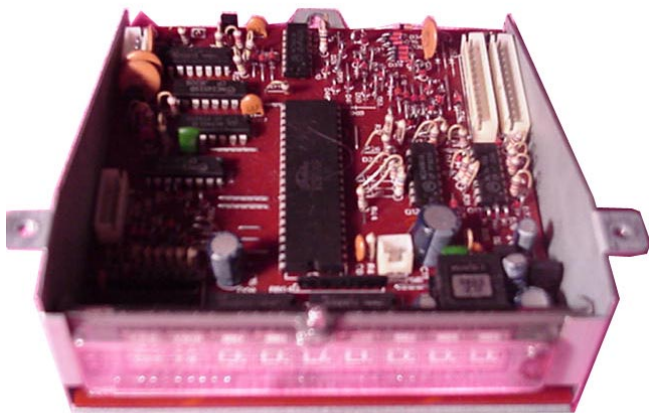

PB2346A COUNTER UNIT

The 0.5 to 1.0 Mhz sample signal from the Local Unit is buffered by Q-5001 (2SC1815Y) and again by a gate in Q-5005 (MC14011B) before being applied to Q-5006 (MC14022B) for gating and division by 8. Output from Q-5006 is then applied to pin 37 of LSI Counter Q-5007 (TC-5070).

The 25 khz clock signal from the Local Unit is buffered by Q-5002 (2SC1815Y) and divided by 25 and by 50 at Q-5003 (MC14518B). The resulting 1 Khz output is applied to SCAN LOCK pin 22 of Q-5007, while the 500 hz output is passed to Q-5004 (MC14518B) for further division by 10 and by 50. These outputs are summed in Q-5005 resulting in a gating pulse for Q-5006 and LOAD PRESET input to pin 32 of Q-5007. The 10 hz output from Q-5004 is also delivered through a gate in Q-5005 to provide a STORE pulse to pin 16 of Q-5007; and to Q-5006 for gating control.

Preset data for Q-5007 is furnished by the bandswitch through encoders Q-5012 and Q-5013 (MC14081B), and by the mode selector through Q-5011 (MC14011) for a 700 hz CW shift and plus 500 Khz for appropriate band selections. Digit driver Q-5009 and Segment driver Q-5008 (both TC5066) pass the output of Q-5007 to fluorescent display DS-5001 (FIP9E8), while Q-5008 (TC-5066) passes mode display information to DS-5001.

The 8 volt DC bus is regulated by Q-5015 (78L05) to provide the 5V supply for the IC's, while the 8V bus is applied directly to the DC-DC converter formed by oscillator Q-5014 (2SC1815Y) and T-5001 (E142) supplies negative 10 Volts DC for the display and for delivery from J-5006 to the -10 volt DC bus.

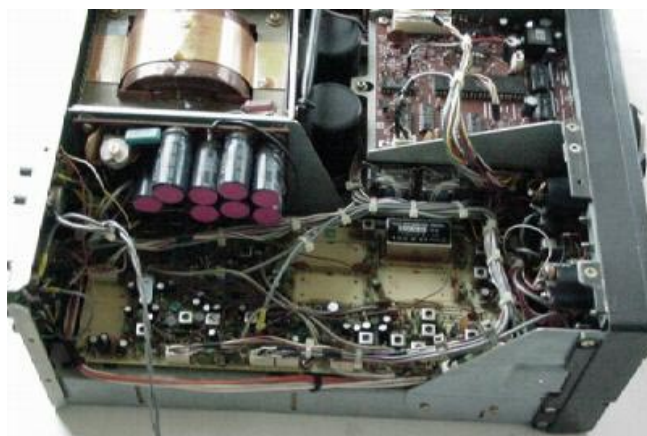
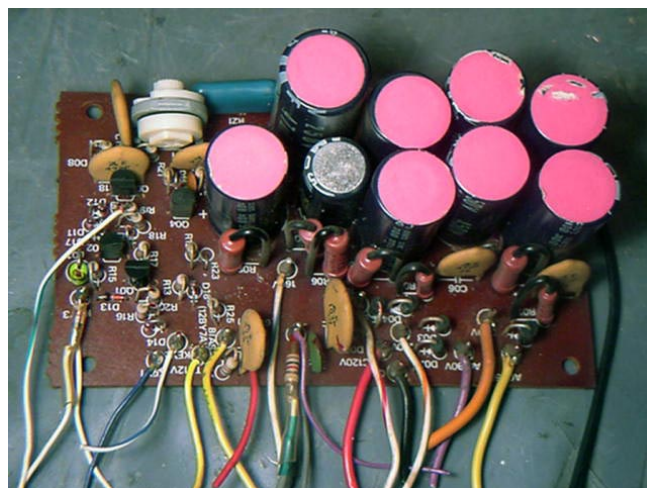

PB2349A RECTIFIER A UNIT

Power transformer PT01 delivers 120, 190 and 250Vac for rectification on Rect A Unit. The 120V input is rectified by D-8006 (10D10) and then filtered to provide grid biases for the driver and the final tubes. VR-8001 adjusts the bias voltage for the finals and the biases are keyed as described in the CW Transmit Operation description. The 190V input is rectified by D-8002 and D-8003 (10D10) and then filtered, after which a portion is pulled down to 180Vdc for the screen voltage to driver V-1001 on the RF Unit. The remainder is passed through diodes D-8004 and D-8005 (10D10) to provide 210Vdc for the screen grids of the final amplifiers. The 250V is rectified by diode D-8001 (SM1-12) and then filtered before delivery (as 300Vdc) to the plate of driver tube V-1001 on the RF Unit.

ALC circuit

On RECT A Unit the grid bias to the final power amplifiers is sampled by Q-8004 (2SC2229). A resulting DC voltage appears whenever the grids of the final tubes are driven positive with respect to the bias voltage, as grid current starts to flow through R8021, causing a voltage drop that is then amplified by Q-8004 for delivery to the IF Unit.

On the IF Unit a portion of this ALC voltage is fed to the gate of second IF amplifier Q-2003, varying the gain of this stage to limit the drive level to the RF Unit and final amplifiers during transmission.

The incoming ALC voltage is also amplified by Q-2029 (2SK19BL). A portion of the output from Q-2029 is applied through meter amplifiers Q-2031 (2SK19TMGR) and Q-2032 (2SA564A) for delivery through T/R relay RL-2001 to meter II during transmission. The remainder of the output from Q-2029 is buffered by Q-2033 (2SC1815Y) and amplified by DC amplifiers Q-2034 and Q-2035 (2SA564AR) which, together with Q-2030 (2SC1815Y), make up the peak-hold circuit.

Q-2030 gives a constant voltage output proportional to the charge retained at capacitor C-2155, which is charged by the ALC voltage from Q-2033 when the ALC METER peak hold switch on the front panel is depressed. The constant output from Q-2030 is then fed to meter amplifier Q-2031 in the same fashion as normal ALC for meter indication.

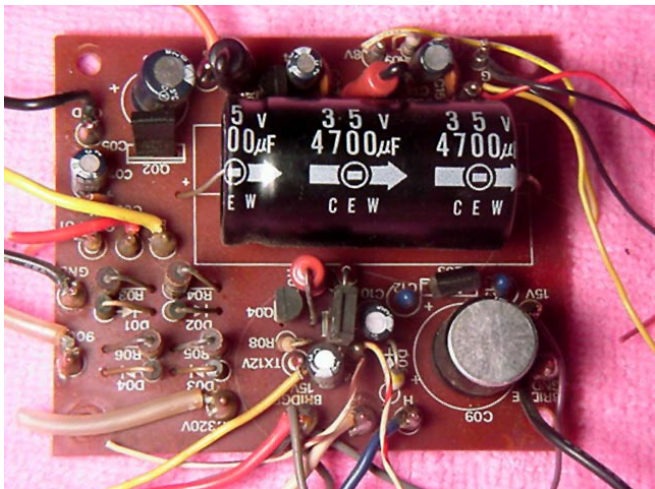

is regulated by Q-8503 (2SC496Y) and zener diode D-8501 (AW01-24) to provide 24 Vdc for the receiver frontend circuits on the RF and IF Units.

A portion of the 24 Vdc is further regulated by Q-8505 (78L15) to provide 15Vdc for the Width Control system. During transmission, 12Vdc is applied to Q-8504 (2SC1815Y) which then grounds the base of Q-8503, dropping the 24Vdc and 15Vdc lines to zero and thus disabling the sensitive receiver front end and the Shift/Width function.

The power transformer 320Vac winding connects to the Rectifier B Unit where the AC is rectified by D-8501 through D-8504 (10D10), and then doubled by capacitors C5 and C6 (on the main chassis) to result in 900 Vdc for the plate circuit of the final amplifiers. Also when a plug is not inserted into the EXT VFO jack on the rear panel, 8 Vdc is delivered from the 8 Vdc supply bus (regulated from the 12 Vdc bus by Q2 (uPC14308), on the main chassis) to zener diode D85-6, producing 6Vdc for delivery to the VFO unit.



When Foxes Tango, everybody is happy !

PB2350 RECTIFIER B UNIT

Bridge rectifier D1 (S4V10) on the main chassis delivers 15 Volts DC to this board where it is filtered and regulated by Q-8501 (2SA733), Q8502 (uPC78L12) and Q1 (2SB705R on the main chassis) providing 12Vdc as the general VCC supply to all other units and to the cooling fan through the HEATER switch. On the main chassis a portion of the 15Vdc present at the emitter of Q1 is diverted to regulators Q3 and Q4 (uPC7812H); Q3 thus providing 12Vdc for the panel lamps and Q4 providing 12Vdc to pin 2 of the EXT VFO jack on the rear panel for the external VFO supply.

AC voltage from the heater winding of the power transformer is rectified by D-8505 (V06B) and filtered by capacitor C-8509, where the filtered 15Vdc from bridge rectifier D1 is added to result in about 26Vdc. This voltage



Yaesu FT-102 Line Accessoires

SP-102 External speaker.

External speaker with a large 120mm HiFi speaker and a selectable high-cut and low-pass filter, allowing for 12 different frequency response curves. With headphone connector, 2 front selectable inputs.

SP-102P External speaker / Phone Patch.

Combines a communication quality speaker response with a hybrid phone patch, with a line meter, gain control. This type has no selectable input, or a selectable audio filter.



FV-102DM External synthesised VFO

Combines a advanced frequency control to the nearest 10hz and a programmable 12- frequency memory for optimal operating convenience, ideal for contests or DX hunting.

The PLL synthesizer steps in 10hz rates, with slow or fast scanning mode, that can be used from the frontpanel of the FV-102 or direct from the special scanning handheld microphone. The memory frequencies can be entered direct from the FT-102 or from the FV-102.

There are additional controls for the scanning rate, 5 or 20 khz, VFO dial lock mode, last digit blanking, transmit/receive split from VFO or Memory.

The VFO dial can also be used as clarifier. The FV-102 has a 5-digit digital display with a resolution to the nearest 10 hz.



FC-102 Antenna Coupler

This is a very versatile Antenna Tuner with a Power handing capacity of 1.2 KW input.

Bandswitched L/C Pi network, that can match a wide variety of antennas, including a single wire antenna, to the FT-102 or a linar amplifier on all HF bands.

Included: A in-line wattmeter with 3 ranges: 20/200/1200 watt, with a peak-hold system for observing peak power output with ease. The FC-102 has a separate SWR meter.

The FC-102 uses internal relays for low-loss push-button selection of 2 antennas and two transmitters.



FAS-1-4R Remote antenna selector

This remote antenna selector allows for the remote switching of 4 additional antennas, direct from your FC-102.

It may either be mounted inside the FC-102 Antenna Coupler or it may be mounted right on your tower, reducing the use of coax lines to your shack.

The unit is controlled by a control line from the FC-102.

The unit has a waterproof diecast housing, which hold the 4 independent relays.

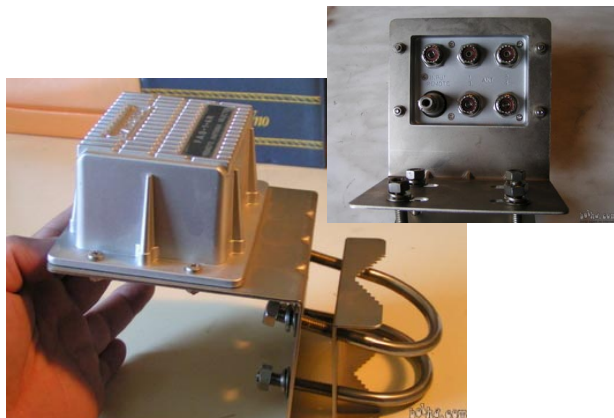

**dB conversion table as used by Yaesu for alignment of their equipment.
0 dBu = 0.5uV/50 ohm**

Yaesu values used in manuals **HP 606A signal generator**

dBu	Volts	dBm
-6	0.25uV	-119
0	0.5uV	-113
6	1uV	-107
12	2uV	-101
24	8uV	-88.9
30	15.8uV	-83
40	50uV	-73
50	158uV	-63
60	500uV	-53
70	1.58mV	-43
80	5mV	-33
90	15.8mV	-23
100	50mV	-13
	224mV	0
120	500mV	7

(dB table courtesy of Jerry Becker)

Filters for the Ft-102



First IF: 8.2 Mhz

<i>Type</i>	<i>Poles</i>	<i>Mode</i>	<i>Bandwidth</i>
XF-8.2HS	8-pole	SSB	2.9 khz

(this is the standard filter)

Optional filters:

XF-8.2HSN	8-pole	SSB	1.8 khz
XF-8.2GA	3 monolith	AM	6 khz
XF-8.2HC	8-pole	CW	600 hz
XF-8.2HCN	8-pole	CW	300 hz

Second IF: 455 khz

<i>Type</i>	<i>Poles</i>	<i>Mode</i>	<i>Bandwidth</i>
CMF-455J1	3-pole	SSB/CW	2.9 khz

(this is the standard filter)

Optional filters:

XF-455C	8-pole	CW	500 hz
XF-455CN	8-pole	CW	270 hz

Not all filters can be placed at the same time, see your manual for possible combinations.

Yaesu Serial Numbers

The Yaesu serial number on the back of the set consists of a number, a letter and 6 numbers. You can see now at a glance the age.

The **first** number is the year of production:
9=1979, 0=1980, 1=1981 a.s.o.

The **letter** is the production month:
C= jan, D= feb, E= march, F= april a.s.o.
(A and B are pre-production runs and not used)

The next 2 numbers are the production run: from 01 to ??
The last 4 numbers are serial numbers: from 0001 to 9999
So in every production run there are maximal 9999 units.
The 6 digits together form a unique serial number.

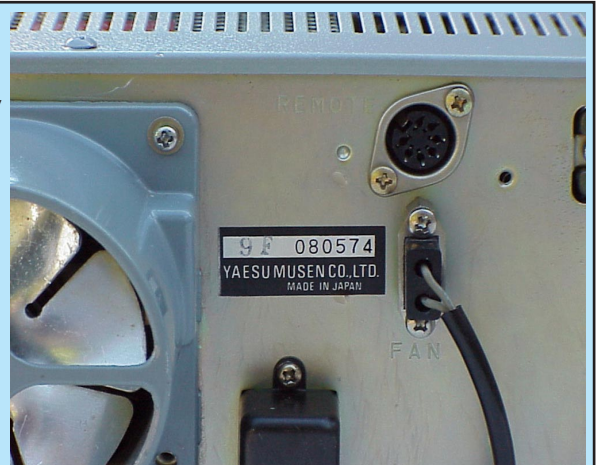

Yaesu 102 Factoids by Malcolm NC4L

see his webpage at: www.members.aol.com/NC4LMal



The FT 102 was designed by the same fellow who later designed the receiver for the 1000D. The receivers are basically identical until the last IF where the 1000D incorporates the DSP functions. In fact the 8 MHz IF frequencies are identical and both radios incorporate variable IF Shift, Width and Notch filters in the same way. All three of those controls are only found in the flagship radio of each manufacturer since they are costly to install in the IF chain.

IF filtering is superior to DSP filtering since IF filtering affects the AGC loop and DSP filtering is usually only in the (post detection) audio loop. This means that notching a carrier in the SSB mode by a DSP mechanism still leaves the effects of that carrier in the IF circuitry and consequently that signal's interfering effect on AGC functioning. With IF filtering the signal is removed from the IF stage and therefore its effects on the characteristics of the IF and AGC circuitry are also eliminated.

Are you aware that if you have an auto notch DSP filter you cannot use it in CW because it will track the loudest tone? On the other hand IF notch filtering is good in any mode.

The third order intercept in the 102 as measured by QST labs in 1984 was +19.5 dBm. That is noteworthy because no other radio has equaled or exceeded that figure as of December 2003.

The 102 utilizes three 6146B tubes for the finals. This enables the 102 to key down over 175 watts in CW and over 200 Watts peak envelope power in SSB. As opposed to transistor finals, PEP can be higher than Key Down power with tube finals because the High Voltage capacitors charge to a higher voltage during the pauses between words and syllables. This is also responsible for the fact that the 102 when properly adjusted can yield 110% modulation in AM and the transistor finals in today's radios just can't do that. With the usual transistor final in today's radios, AM modulation is ordinarily 50%.

Did you know that the percentage of AM modulation is responsible for your apparent loudness and the carrier or unmodulated power is responsible for quieting the background noise? The best situation for getting thru and being copied is at 100% or slightly greater modulation.

The 102 does not have a synthesizer and therefore reciprocal mixing products resulting from the synthesizer noise mixing with strong signals above and below the listening frequency will have no effect on the listening frequency.



This manual is a courtesy to you from **Fox-Tango International**, with contributions from Carol W4CLM, Mal NC4L, José EB5AGV, Wim PAOPGA, and many other FT-102 lovers.



BLOWING FUSES IN YOUR 102 ???

If you are blowing fuses in your 102 in transmit there are a couple of things you might want to know. Below is my email answer to a fellow ham who had the above problem.

Hello Mario,

Yes, that problem is the second most common problem with the 102 and is caused by the 6146 going into thermal runaway.

The problem is as you described - an increase of the resting cathode current which starts out at 75 ma and gradually and then quickly increases until the fuse blows within a 10 minute time span. This will happen in SSB, even if you do no talking and shut the mic. gain down. There is only one cure and that is to get a new set of tubes as the ones you currently have in your radio have had the screen and control grids permanently deformed by excessive heat.

I mention cathode current as your meter does not indicate plate current. The measurement circuit is inserted in that part of the circuit between the cathode of the 6146s and ground so that high voltage insulation is not required for the measurement circuitry. If you look at the bottom of the power amp board (solder side) you will notice a white component (before it is thermally damaged and charred) which looks like an inductor because it is coiled. This is just a coiled resistance wire with a white fabric insulation over the wire. This is the shunt resistor connecting the cathodes to ground. It is about 0.6 ohms and the meter circuit works from the voltage developed across this resistor when current flows in transmit.

The problem of the runaway cathode current is almost always caused by improper tune up procedures. Most hams know the "10 second rule" where they do not key

down for more than ten seconds but many forget that they must stay keyed up for ten seconds because the tubes are only rated for 50% duty cycle. In fact I recommend that you key up for 15 seconds for every 10 seconds on time when tuning up. The extra heat which is generated by doing the procedure wrong deforms and warps the grid assemblies and once this happens it is a permanent abnormality. Most hams only know the fuse blows as they keep their meters in the power position and you will not see any abnormality when looking at the power output since the abnormal extra current does not generate any additional power to the antenna.

Most hams especially if they are older get angry with the radio and so they keep putting in larger and larger fuses or slow blow fuses. This results in several problems such as the set catching fire, blowing the transformer, shorting the choke supplying the 6146s (should measure more than 4.4 ohms) and cooking the shunt resistor. I have seen these damages over and over. This is the main reason that the 102s wind up in the radio graveyard. I now have ten parts radios which were purchased from people who did not want to go to the extra expense of replacing the transformer and didn't want to pay to ship a broken and smoke smelling radio back. There are many other radios that I would not make an offer to buy as I now have plenty of these parts radios.

I recommend the following test:

Place the set into transmit SSB and turn the mic gain to off with the meter switch in the IP position so that you are looking at the cathode current. Your static cathode current should read about 75 ma.. Keep the set in transmit for the next ten minutes and make sure the current does not show an increase of 25 ma over the starting value after a ten minute time span. The best tubes will show no increase on your current meter while fair tubes will show no more than a 25 ma gain. Anything that exceeds a 25 ma. increase, will blow fuses - if not at the time then in the near future.

So please get a certified set of new tubes from a reputable wholesaler (not on ebay) so that you can be sure the tubes you purchase are new and not someone else's pulls because they noted the same problem. Most people when replacing tubes put the pulls in the new boxes and over the years forget (sometimes intentionally) that they are not good.

In addition please check that the resistance between the top and bottom connections of your choke (please make sure that the high voltage has been discharged) is more than 4.4 ohms as when the choke is subjected to excessive currents, sections of the choke short out. That results in decreased output on the higher bands like 10 meters.

If your shunt resistor's insulation (different from the choke) is charred leave it alone as there is no problem with this. It does not need to be replaced.

And lastly make sure that you do not use more than a 5 amp quick blow fuse.

Suggestions to get the best out of your 102

Shift and Width Controls:

The shift and width controls are intended to suit your personal preference by giving you the ability to customize the sound of your rig and minimize interference. The gray zone on the controls represents the width of your passband. Turning both controls at once via the friction lock, either clockwise or counterclockwise, shifts your passband but does not change your bandwidth. The gray area remains the same size. Both filter slopes move in tandem. This is used when you want to eliminate interference that is only on one side of the signal that you are listening to as it gives you two filter slopes that reinforce each other (one from each of the two IF filters) as rejection fighting devices. (First three photos)

If you rotate one control against the other, the gray area will become smaller = narrowing of the passband width. (See photos 4,5,and 6 below). One edge on the control will be a chrome gray border and the other border will be a gray against black border. This is used to reduce interference from simultaneously transmitted signals where one is above your frequency of interest and the other is below. In this instance one filter's edge is used on one side and the other filter's edge is used on the opposite side. The chrome against gray border is the effect of the 8.2 MHz filter and the gray against black is the 455 KHz filter edge. When the gray area is at its widest (chrome to gray borders at both sides) both filter edges are coincident and the passband of each is the same and they reinforce each other.

You may find that certain combinations of rotation of each of the friction locked controls to be pleasing to your ears. This is then the way the control should be set for you. There is no law that states that both controls must be centered and vertical.

If you adjust this double ganged friction dual control for the three above variables (pleasant sound, interference rejection to one side or interference rejection on both sides of your passband) you will begin to realize the potential of your 102 and why this control format is the best around. I can't begin to tell you how many hams don't understand the concept of the triple function of this control. There is nothing else like it in ham radio as the control of these functions in other radios takes two to three separate controls and you have to toggle back and forth between those. By the time you get it right with two separate controls your station has stopped transmitting.

I believe this misconception stems from the instruction manual which is not very clear on the usage of the control. With all of this in mind, let this control become an extension of your brain and ears. Learn how to manipulate it with your thumb, pointer, middle finger and wrist of one hand (all three functions at once) like playing a musical instrument. After some practice and getting used to the adjustment procedure you will find every other type of radio awkward and cumbersome to adjust.

73 de NC4L Mal

One more note here – the controls work differently in USB and LSB so that a clockwise turn on USB produces the same effect as a counterclockwise turn on LSB. The controls are reversed in the opposite sideband.

The digital display:

Since the digital display in the 102 is in reality a hybrid frequency counter it is probable that when you are on the border of the next 100 cycle segment there will be a flicker of the last significant digit. This has no effect on the stability of the frequency of the radio and only represents



that point where the counter at one counting (updated five times per second) sees either of the two rounded readings and can't quite decide into which number it should place the display. In reality this zone is 4 cycles wide.

In other radios such as a Kenwood 430 (just as an example) the display number is generated by a divide by function of the computer chip. This display will not change no matter how much drift there is in the operating frequency because it is not a counter but a rather a mathematical number processor. If you adjust the master oscillator frequency in a 430 the radio will change frequency drastically but the display will not move. I personally believe it is better to have a counter so you can observe any drift rather than having the drift be hidden from you (even though you have to put up with the flicker).

The RF amp button:

If the S meter reads the background noise level at more than an S 5 with the RF amp button depressed (= on) my recommendation is turn the function off (=out) as you don't need the extra sensitivity. If the control is out (= off) the front end is bypassed and the signal goes directly to the first mixer for even better receiver performance. This is the same as the AIP control in Kenwoods and the IPO function in the newer Yaesus.

On the other hand if the background noise level is less than an S 5 with the control pushed in (=on) then leave it on.

Sensitivity on 20 meters is usually .15 uV (or better) for 10dB S+N/N with the control pushed in and .6 uV for 10dB S+N/N with it in the out position. If you leave the control depressed when the bandnoise on receive is above S 5 on your S-meter (such as on 80 meters) that noise will be adjusted by the ALC to the same intensity at the speaker as the signal you are listening to. It will therefore make copy more difficult.

Noise Blanker:

When using the noise blanker with very strong signals nearby or even on a strong station that you are listening to, severe distortion products may be heard. In this instance just turn the level control down and the signal will clear up. A good zone should be obtainable where there is effective reduction of the pulse noise and a good clean copy on your signal of interest. Sometimes I am listening to a very weak station and have the noise blanker turned way up and another station that is strong breaks in. Distortion will be heard so always check to see if the control is engaged and how high the level is set.

Tune up:

I have included instructions for proper tune up of the radio. Most important here is the rule of "ten on and ten off". This means that the maximum continuous key down time at full output should not exceed ten seconds. And even more important is that in addition you must wait ten to fifteen seconds between key downs.

If you don't follow this rule you will be making trouble for yourself and waste money needlessly because you will be exceeding the safe dissipation ability of the tube and the extra heat generated will deform the grid and screen in the 6146s. When the tube has been poisoned in this way you will start to get thermal runaway where the cathode current creeps up and will blow your fuse (watch the IC position of your meter if this happens). Do not replace the fuse with anything larger than a 5 amp quick blow fuse and replace the tubes. Nothing else will effect a cure once the fuses start blowing.

When the tubes have been heat damaged it will take five or ten minutes at first in transmit for the fuse to blow. The times will become shorter as time goes on. If you use a larger fuse or a slow blow fuse, one of two things will happen – The radio will either catch fire or blow the transformer and choke. This course of events is the main reason that 102s go to the graveyard.

Although I can repair the resultant damage, the radio usually smells from fire and I cannot undo that or the liquification of the lacquer from the transformer windings which get deposited all over the controls of the local board making adjustment of those controls in the future unreliable. So the radio then goes to the parts graveyard.

SSB TRANSMIT:

And lastly in SSB, I recommend that you do not run the ALC in transmit above S3 to S5 for best audio clarity. Running the ALC meter into the S9 range acts like a processor and yields 10 dB of compression. It will give you more punch but with some mild loss of quality.

CW TRANSMIT:

Some of the earlier models of the 102 had a problem with Key Clicks on CW. By serial number 050xxx Yaesu had it cleaned up. Let me suggest that when working CW and after you tune the transmitter cut the Drive control back until the ALC no longer comes up off the peg. At the same time make sure you still have maximum power output. It is an easy adjustment with the two meters and the Drive control. This will give you very sweet CW characteristics with beautiful shaping of the leading and trailing edge of your CW note. This will eliminate Key Clicks in the early models and make the later models sound even better.

If you follow the suggestions above your 102 will be the most reliable radio you have ever owned with the only upkeep being tube replacement every five to ten years under heavy usage. You will also get the best performance possible from your rig.

Thanks for looking this over. Enjoy your 102 and get a hold of me if you need any questions answered (954-961-2034 in the evenings).

73 de NC4L

THE EB5AGV RELAY MODIFICATION

Fellow 102 enthusiasts,

I have often been asked about the EB5AGV relay modification for RL02 in the 102. I am not happy with this modification for several reasons. I responded to a fellow ham in an email about this and thought it would be a good idea to put that letter and photo up on my 102 website for your enjoyment and education. I hope you enjoy the explanation and photo.

NC4L Mal

Hi Fred,

Yes, I have seen the EB5AGV mod for RL02 several times in radios that I have worked on and it is a mess. I have enclosed a side by side photo of the trace side of the board for comparison. Because the pinout configuration of that relay is different from the original, several traces have to be cut and rerouted. This crosses sensitive RF lines and decreases the performance characteristics of the radio.

I am sure you know that the component and trace placements on the board are not a matter of happenstance but rather are placed in certain ways after much experimentation by the designer to improve cross-talk and non wanted signal mixing. The EB5AGV modification changes the benefits of the manufacturers design by moving the lines and crossing the lines. When I measure blocking dynamic range of an unmodified radio I get -127 dBm at 20 KC spacing. When I measure this on the modified radios I get -124 dBm which is a halving of the figure.

In addition it is a very hard modification for most hams to do. The plastic socket has to be soldered and wired and the pins are on 1/10 inch distances. If you use anything but a fine pencil iron and do not have expert proficiency at soldering and perhaps your vision isn't like a teenager, you will make a mess of this modification. In addition most hams use soldering irons that are too hot and lift the traces.

The mod does work but at an expense of performance. But my real complaint about it is that he makes it look easy and a lot of guys will try it. When they get into trouble they will be left with a cut board with lifted traces and will stop working on it out of frustration. And presently this is probably the main reason that the 102 goes to the radio graveyard.

Check the photos.

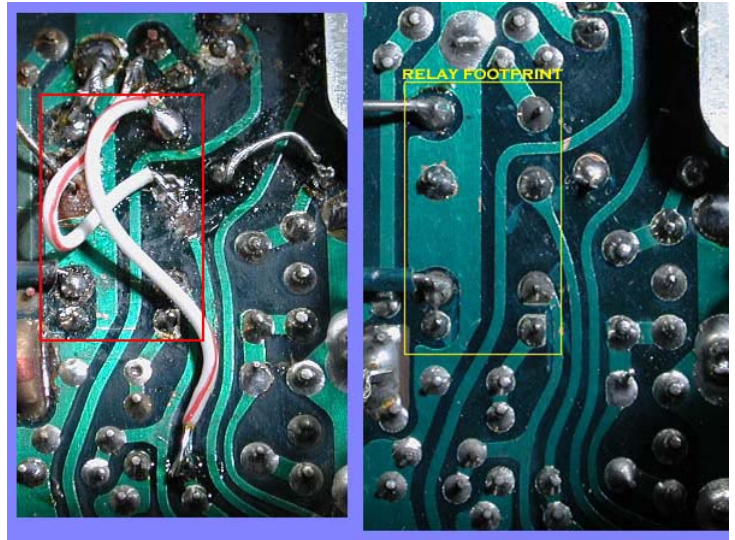

Modified board

Normal Board

I hope you can see the cause for my concern that this is on the web.

There is one other alternative to the RL02 Problem and that is using a small signal relay made by Teledyne corporation. This relay is enclosed in a metal can and looks like a transistor with eight leads coming out of it. Small signal relays are a special type and there is no degradation of the contact resistance over time if only small signals are used.

I like this repair since the relay is metal enclosed and shielded from RF. It is also a good choice because a socket does not have to be prepared and there is no cutting and rerouting of the traces on the board so it is an easy modification. Unfortunately, some twisting of the lead wires has to be done since the pin out configuration is not the same but I figure the loss here would be compensated for by the fact that the relay is enclosed in metal and shielded from stray RF. The disadvantage is that the relay is \$20.00+ in cost The model number is Teledyne # 712-12.

73 de NC4L

Mal

onliner: Experience is what you get when you don't get what you wanted.

Yaesu power meter modification

Over the years I have been bothered by the fact that the relative power output meter in the 102 is under damped in SSB mode. This results in minimal meter movement even though a radio can be putting out in excess of 200 watts on SSB peaks. This modification will not in any way affect the set power levels for continuous wave outputs like CW or FM or Tune. It will however make your meter move much more responsively and energetically in the Single Side Band mode

The Modification takes about 10 minutes. It uses one 10uF electrolytic capacitor and two solder connections. A photo tutorial of the mod follows. It is easy and fun to do and will permit your set to function better.

The first step is to remove the top cabinet of the radio and remove the fast-on connectors for the speaker so that you can place the top case aside.

The first photo shows the radio with the case off and the area where you will be working.

The second photo identifies the variable pot for adjusting the meter. This pot does not have to be adjusted but you will have to solder the capacitor onto its outer terminals. The photo identifies the ground (yellow) and hot (pink) leads. The middle post is the wiper arm and is not involved in the modification.

I used a radial lead 10uF capacitor (both leads come out the same end). The voltage limitation is not very important because it is in a low voltage circuit. As can be seen in this photo the leads are bent 90 degrees in opposite directions so that the cap looks like a ballerina doing a split.

The fourth photo shows that the leads are bent again at 90 degrees so that they face in the same direction and are parallel and 1/2 inch apart. This will match up with the terminals of the control. The leads are also trimmed to about 1/2 inch – again see photo #4.

The stripe on the capacitor indicates the negative terminal and so you solder this to the left lead as indicated in the photo. The positive lead is soldered to the right post and that is it.

When you bend the leads note where the negative stripe is and the orientation of how you will place the cap into position. If you have done the second bend in the wrong direction – just rebend the leads. It should look like the final photo.

Hams are by nature resourceful and industrious so that if you have an axial lead capacitor at hand (one lead comes out of each end of the cap) just apply your intelligence and skill to complete the job.

Now button up the radio and note the increased responsiveness of the meter. If you want more movement — you guessed it – use a larger capacitor, but it should be an electrolytic and polarized.

That's it folks – Have fun. I hope to have more mods in the future.

73 de NC4L Mal

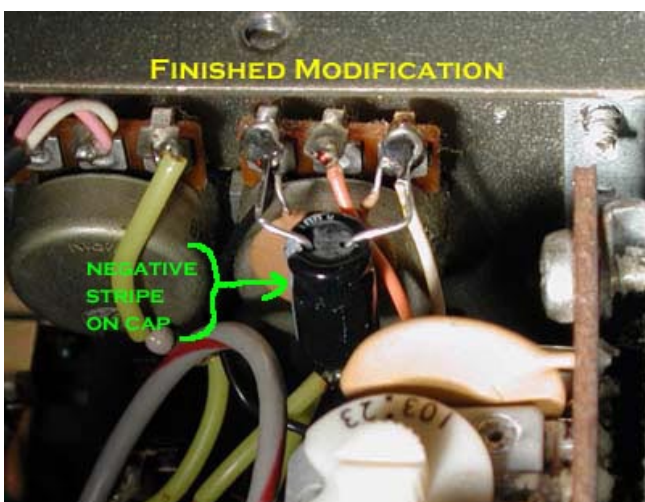
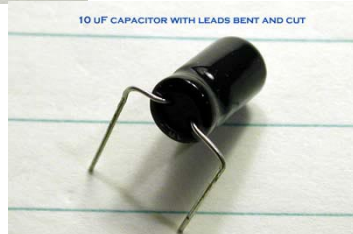
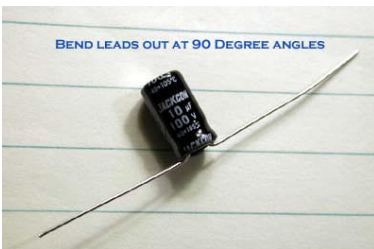
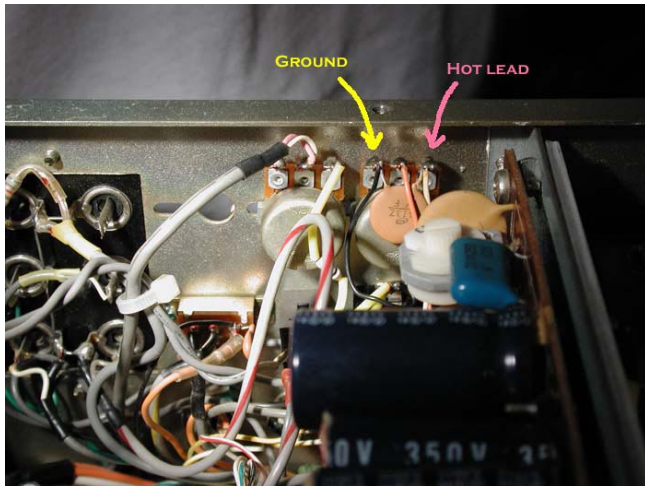
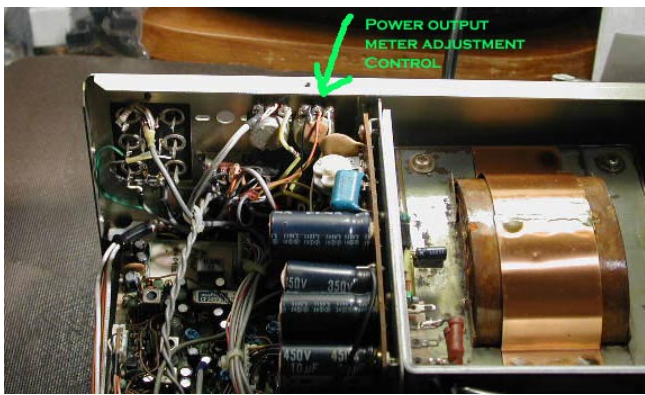

Enunciator Mod for AM

Here is an easy modification for those 102 owners that have an AM filter installed. Unless I have worked on your radio the enunciator (located to the left of the digits in the display) will say AM-N when you switch to AM even if the AM filter is installed. Yaesu apparently forgot to put the switching network and circuitry into the radio to change the letters to AM-W or AM wide.

This modification should take you 10 minutes to do.

Take off only the upper case and place it aside. Locate the display board in the middle front of the radio.

It is not necessary to remove the board from the radio but have it turned off. As the radio faces you find diode 14 on the front left of the display board (see photos). The marking will be directly in back of diode 14. This diode is mounted in a semiverticle position and you will be soldering the cathode of a second diode to the highest point on this (D14) lead. Then identify diode 06 which is the second diode to the right of D14. Cut its cathode lead as far to the front of the set as possible. Then take D12 (which is between 14 and 6) and bend it over 30 degrees to the right so that it is like the leaning tower of Pisa. Next take the cut lead of D6 and bring it behind and around D12 over to the cathode lead of D14 and solder them together. See Photos.

Then turn the set on and check that the enunciator says "AM-W". That's it.

Have fun and contact me if you have any problems.

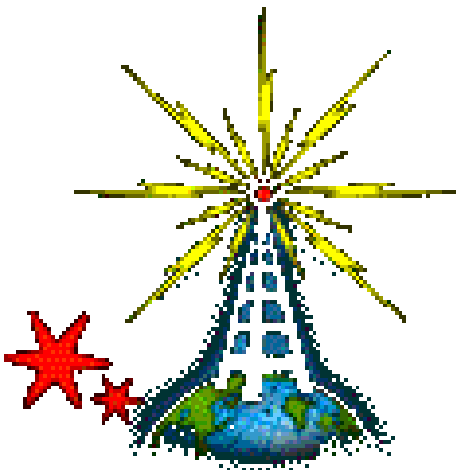
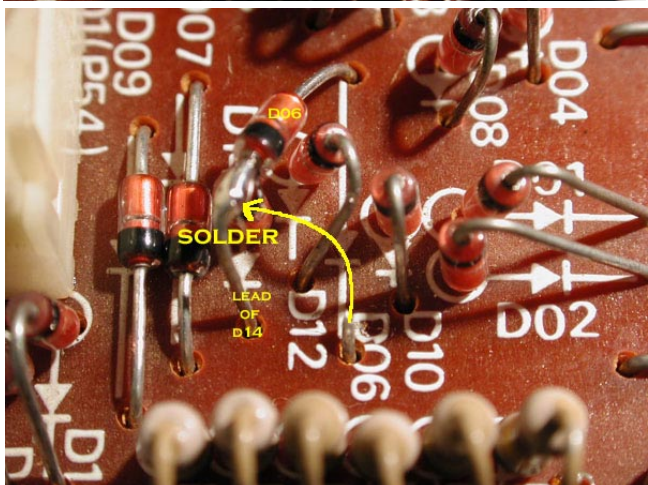
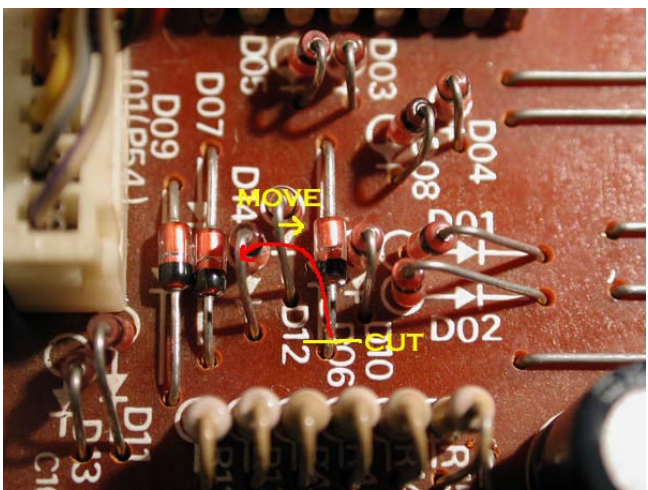
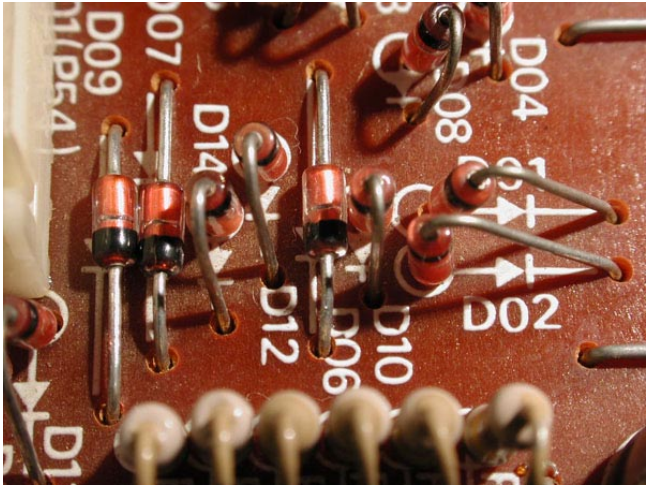
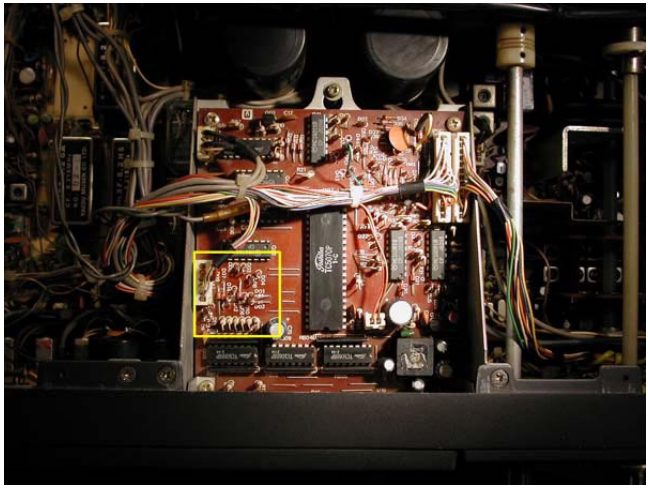

YAESU FT 102 AM SURGE MODIFICATION

10/10/05

Please note - this surge modification in its complete and detailed phototutorial form is at the link below.

<http://www.amwindow.org/tech/htm/ft102overshoot1.htm>

Many folks have asked me to come up with a good AM surge modification for the 102 and so I listened and have come up with an excellent modification that can be done in an afternoon or less.

This modification was prompted by an email from Bill W3DUQ who has also published a mod for the 102 overshoot modification. Bill correctly found that the cause of the overshoot was the 8 volt AM transmit supply line which was unstable at initial onset of transmit while it was going from a resting voltage of 0 to the working 8 volts. He correctly understood that a stable 8 volt supply was needed and had to be on in receive as well as transmit so that there would be no variation of the voltage at the onset of AM transmit.

Below is my email to Bill with the new and simplified modification and its explanation.

Hi Bill,

OK, I have it figured out and it overcomes all the short falls of the initial modification.

Your initial modification had two very serious drawbacks:

1. - The radio and board were neither forward or back compatible. By that I mean that the modified board could not be used in another unmodified 102 and that a modified radio could not accept a normal unmodified AM-FM board.

2. - Because AM is also powered up when FM is selected in your modification both forms of modulation mix and the output on FM is very distorted by the simultaneous AM modulation components.

Starting with an unmodified radio and board cut the wire going to pin 1 of P60 (J01) of the AM-FM unit. Leave enough room (about 2 inches) to solder another lead to it and insulate the other cut end which carried

the old 8 volt supply to pin 1, so it doesn't short out.

Then go to the AF board and pick up a lead from pin 2 of J15/P38. This is noted to be a 12 Volt, AM line. It a yellow wire and is energized only when in the AM mode. It is on continuously in both receive and transmit. It is not on in the FM or any other mode as was the case with your mod.

This line (yellow wire) will be your new power source for the AM unit but it must first be converted to 8 volts. I recommend using a three terminal 7808L (L is for low power) regulator (cost is well under a dollar) to bring the 12 volts to 8V. Then connect the 8 volt output line from the regulator to the wire from pin 1 of P60 and it is done.

This will give you a constant 8 volts at pin 1 of plug 60 - but only in the AM mode and will be activate in both receive and transmit so there will be no variation when going from receive to transmit. This power line will not be active on FM or any other mode so that AM modulation components cannot interfere with FM functions since AM will not be switched on.

The nice thing with this simplified modification is that a modified radio and unmodified boards are both forward and backward compatible. Give it a try. I will publish this to my 102 website at www.members.aol.com/NC4IMal as soon as I find a suitable place to locate the 8 volt regulator and will have a phototutorial on how to do it in the future.

73 de NC4L Mal

This surge modification in its complete and detailed phototutorial form is at <http://www.amwindow.org/tech/htm/ft102overshoot1.htm>

The modification can be done in an hour - just click on the blue link at the top of this page.

73 de NC4L Mal

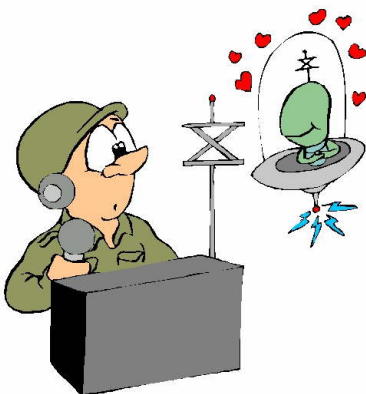

See the next pages for this Mod.

onliner: Basic research is what you do when you don't know what you are doing

FT-102 Overshoot Fix

by Mal - NC4L

** Editors Note: This is a fix to the overshoot modification by Bill, W3DUQ previously posted here. If you have a mod dated prior to 7 December 2004, please read the following and take the appropriate actions - either do the mods below or do not use your FT-102 on FM (see number 2 below). TNX, WB3HUZ.

A Fix for the Previous Modification

The previous modification had two very serious drawbacks:

1. - The radio and board are neither forward or back compatible. By that I mean that the modified board could not be used in another unmodified 102 and that a modified radio could not accept a normal unmodified AM-FM board.

2. - Because AM is also powered up when FM is selected both forms of modulation mix and the output on FM is very distorted by the simultaneous AM modulation components.

The Key Down Surge Problem

The FT-102 has a serious surge or overshoot of power when first keyed in the AM mode. If you are driving a linear, the surge may cause damage to the amp's tubes (or transistors), or cause protection circuitry in the amp to shut it down. Further, even if your amp survives, it is likely to be overloaded for a brief period and the first few words of your transmission will be distorted and cause splatter due to flattopping. Actually, this will occur even if you use the 102 barefoot, although the splatter will be less noticeable due to the lower power. But good amateur practice is to avoid splatter no matter the power level.

Let's look at the severity of the problem. When I look at the power surge on the scope I can see an enormous surge when the 102 is first keyed in the AM mode. I run my rig at 40 watts out on AM. If my carrier is set to 40 watts and I key down the surge extends to over 200 watts.

The reason that surge exceeds my usual steady state key down power of 160 watts (when the mode switch is in the tune or CW positions) is that the 102 is a tube amp and the caps charge higher in any quiescent mode. That used to be called dynamic headroom in the old Hi-Fi terminology. It is also the reason that the 102 can easily exceed 100% modulation in AM on the positive peaks. That cannot occur with solid state driven exciter amps, as the ALC in these transceivers will stop any power increase beyond saturation, stone cold. I usually get all the 102s to run at 110% modulation after peaking

the AM tank on the board and making sure that the voltage inputs to the two circuits on the chip are in the right relationship.

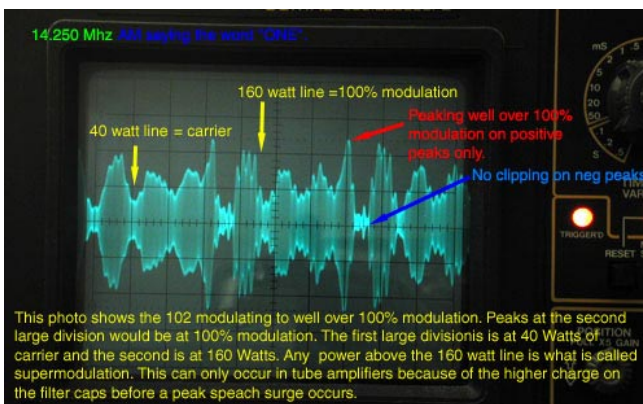

Figure 1 - Scope display of a properly tuned and operating FT-102 on AM.

The key down surge starts at over 200 watts and stays at over 160 watts for 250 milliseconds (mS) and then gradually subsides over another half second. After the modifications described below, there is a minor peak (represents dynamic headroom of the amp) to about 60 watts and then back to normal carrier within 30 mS of keydown. This very small surge will not trip any linear amp protection circuits.

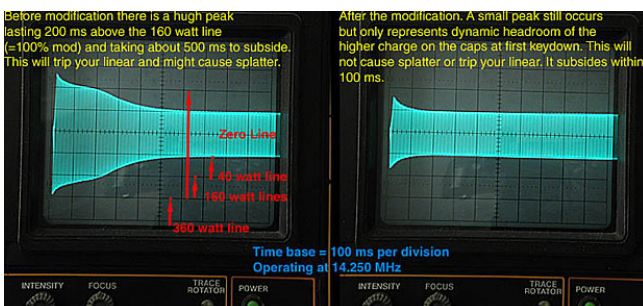
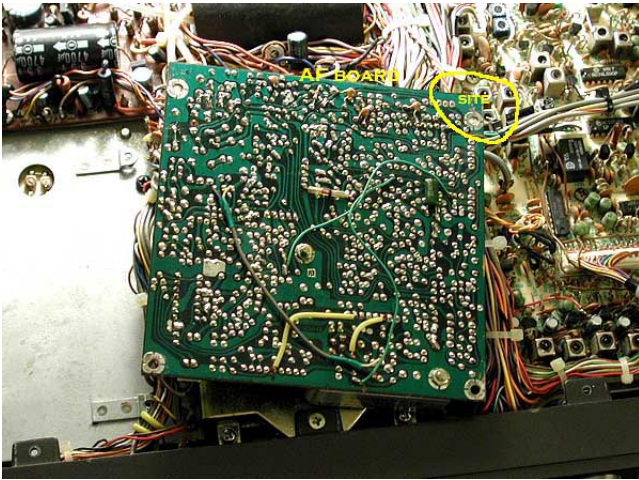

Figure 2 - Scope display of the power surge: before modification at left, after modification on right.

The Modifications

Starting from an unmodified radio and FM-AM Unit (PB-2347), cut the wire going to pin 1 of P60 (J01). Leave enough room (about 2 inches) to solder another lead to it and insulate the other cut end which carried the old 8 volt supply to pin 1, so it doesn't short out.

Then go to the AF Board/Unit (PB-2344) and pick up a lead from pin 2 of J15/P38. This is noted to be a 12 Volt AM line. It is energized only when in the AM mode, and is on continuously in both receive and transmit. It is not on in FM or any other mode. This will be your new power source for the AM unit but it must first be converted to 8 volts. I recommend using a 7808L regulator (cost is well under a dollar) to bring the 12 volts to 8V. The photos below show where and how to install the 7808L on the



AF Board/Unit (PB-2344).

Connect this 8 volt line to the wire from pin 1 of P60 and it is done. This will give you constant 8 volts at pin 1 of plug 60, but only in the AM mode and will be activate in both receive and transmit. This power line will not be active on FM or any other mode so that AM cannot interfere with FM functions since it will not be switched on.

The nice thing with this modification is that this modified radio and the unmodified boards are both forward and backward compatible.

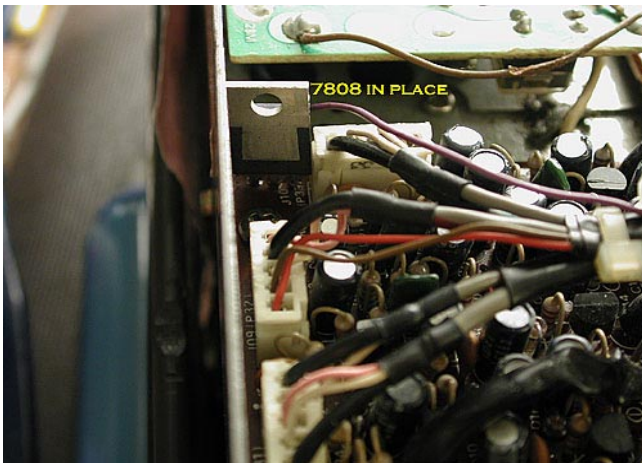

Figure 3 - The regulator (7808) will be placed in the upper right hand corner of the AF Board.

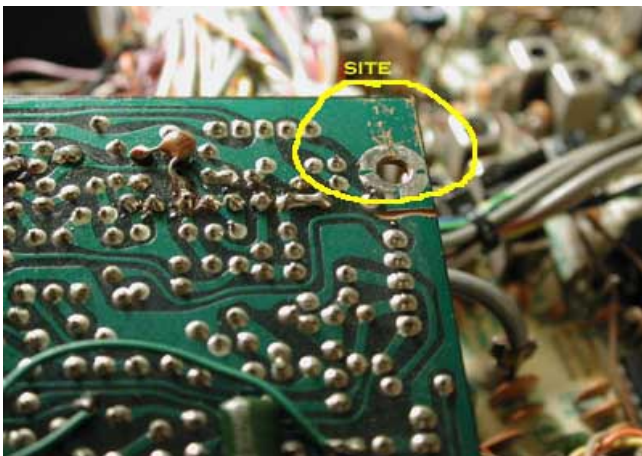

Figure 4 - There is a little unused real estate just above the mounting hole.

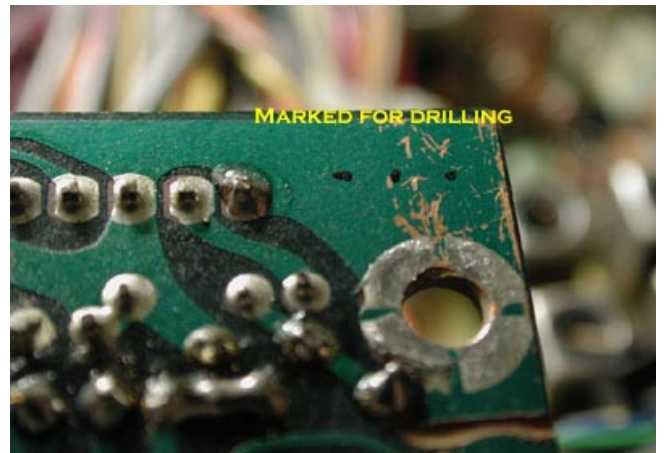

Figure 5 - Using the 7808 pins as a template (or calipers, ruler of some other measuring tool) mark the board and then drill the holes.

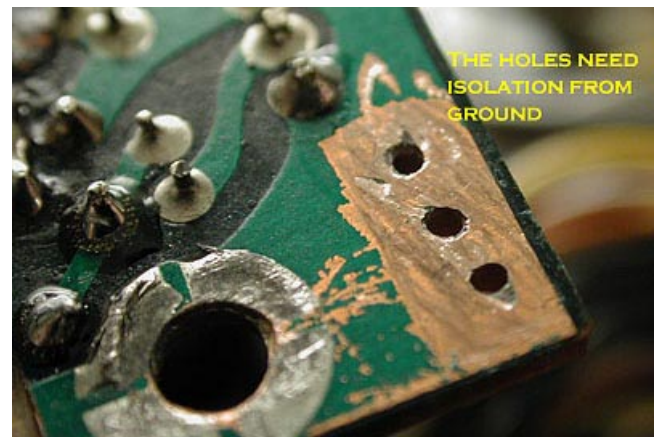

Figure 6 - Scrape off the conformal coating around the holes for about 1/16 inch. I used a Dremel battery operated drill and a dental bit but many other things will work out.

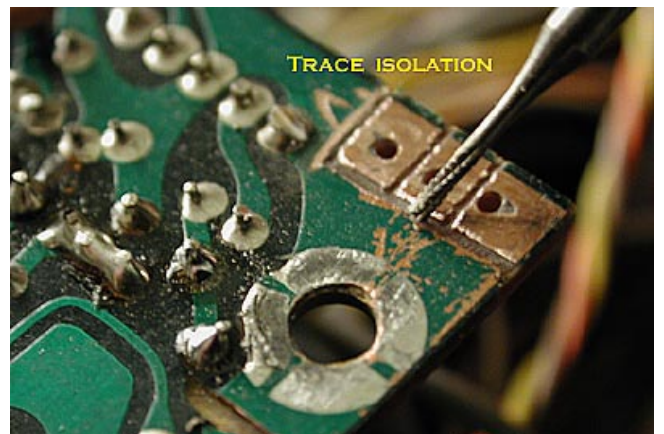

Figure 7 - Scrape away the copper between each hole to make a solder pad for each leg/terminal of the 7808.

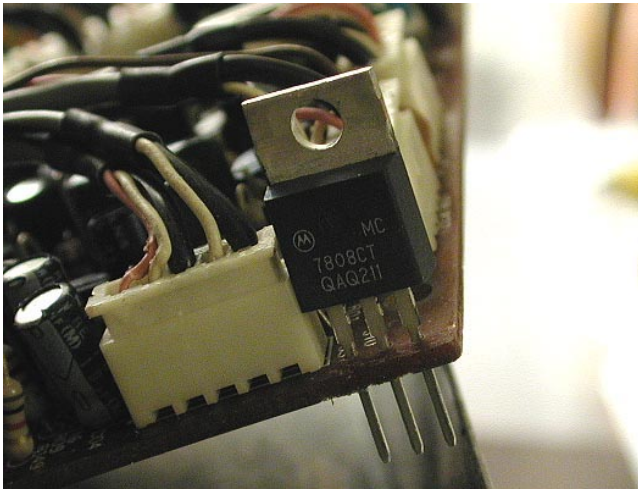

Figure 8 - Be sure to insert the 7808 as shown. Because the radio was rotated 180 degrees to get this photo, please make sure that the printing on the plastic part of the regulator faces away from the board. Polarity counts!



Figure 11 - Reinstall the AF and AM/FM boards and test. Again note the orientation of the 7808 at the time of final installation in the photo. The plastic part with writing should face toward the PA board.

Conclusion

The FT-102 is a great rig for AM, FM, CW and SSB. The mods above will make it a much better performer on AM, especially when using it with a linear amplifier. If you are interested in more information and other modifications on the FT-102, please visit my Web page at www.members.aol.com/NC4LMAL. And if you run into trouble, contact me for assistance at NC4LMal@aol.com.

Postscript

I have to ask for some forgiveness from my readers as I worked out the logistics for the mod in a few minutes and then did it while I took photos with my camera. I was flying by the seat of my pants in a first try attempt and therefore my work was not as neat as usual.

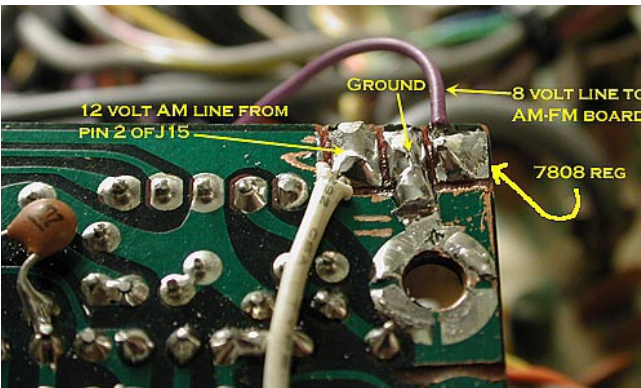

Figure 9 - Solder the connections shown and described in the text above and you are almost done.

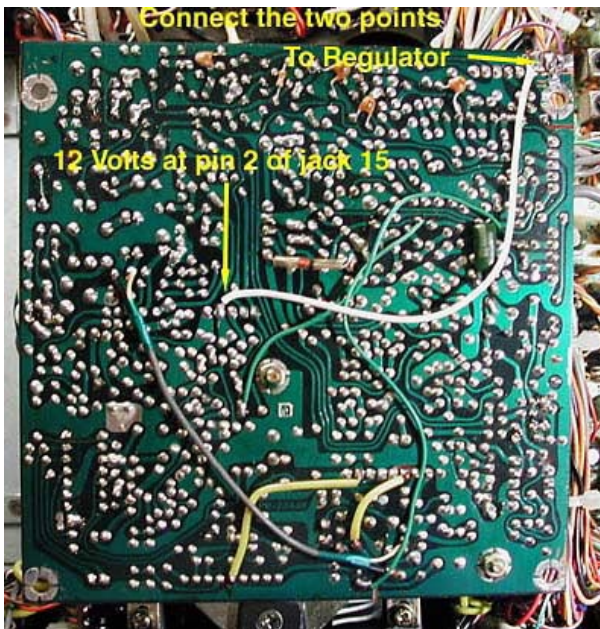

Figure 10 - View of the back side of the completed AF Board (PB-2344).

How to change the meter lamps in the 102

To change the 102 meter lamps ----4/05/03 ---- please read all the instructions first before starting.

-Open top case only - 6 screws from the case but also loosen the handle cover screws two full turns to permit having the upper cabinet case to come up. Remove the speaker leads (push on connectors) and place the upper cabinet aside.

-Remove two screws holding the meter assembly in place (1).

-Carefully remove the brown tape (2&3) and the scotch tape that seals the bottom of the meters. Remove all of the clear plastic tape from the bottom of the meter housing. Discard only the clear plastic tape as you will be reusing the brown tape later.

-(4) With your fingernail pull at the top of the plastic meter housing until it pops off

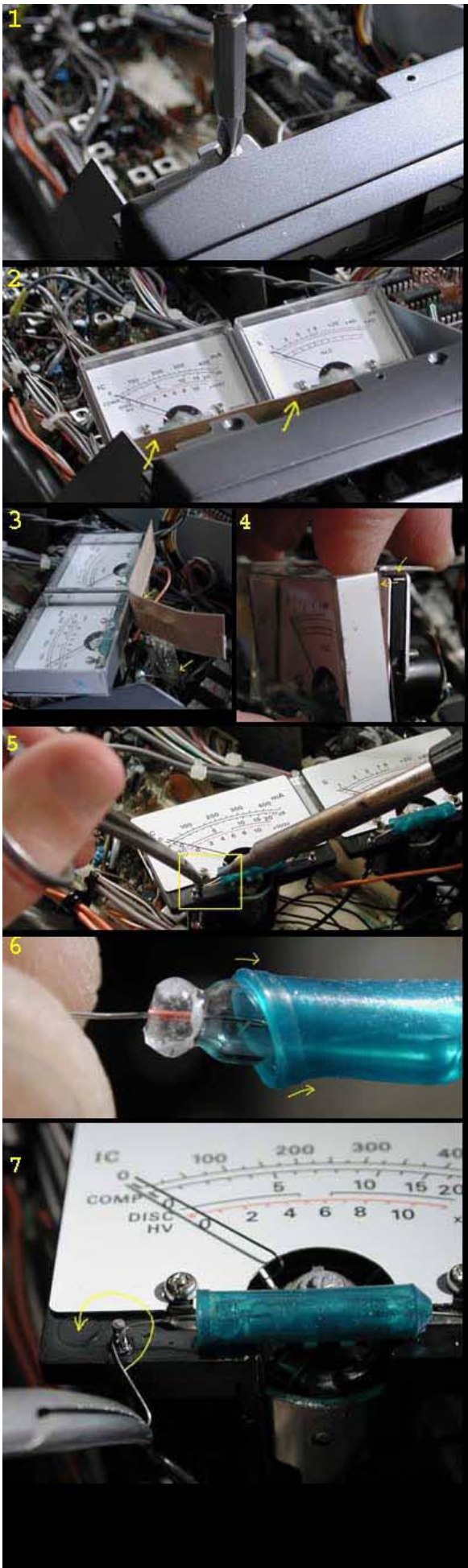

-Unsolder the old bulbs (5) from the posts. Be careful not to use too much heat or the plastic will melt and the pins will migrate or fall out. A hemostat or small needle nose pliers (5) will help you remove the wires from the pins. Use these to grasp the wire firmly at the end closest to the post. Heat the joint and when the solder begins to melt firmly pull the wire off the post (5)

-Carefully remove the blue plastic boot on the old bulb: If you have bulbs with the boots installed these next few steps are not necessary so proceed to the fourth paragraph down which starts with "Grab the lead".

Method 1 - (6) Shimmy the open end of the old boot back across the bulb by grasping the bulb and boot between your thumb and index finger. Hold the lead to the bulb with a hemostat so that you have something to pull against. Work one edge at a time - first your thumb and then your index finger - like swimming or climbing down a ladder. Be gentle at first and then apply more pressure if it doesn't move. It should move only a small but visible amount each time so keep working at it with persistence and it should come off.

Method 2 - roll the open edge old boot back while turning it inside out (forgive me but as in removing a condom). These two procedures are the hardest part of the replacement. It may help if you place the old bulb in some soapy water if you have no success with either method the first time

-Then rinse and dry the blue plastic boot and place it onto the new lamp.

-Grab the lead from the new bulb (blue boot installed) with the very tip of the hemostat (7) and wrap it around the post. Do the same on the other side of that bulb and then do the other meter. Adjust the position of the bulb until the filament is in a position midway between the two posts and then solder the lead to the posts at all four positions. An easier way is to tack the wire onto the post with solder and clip the left over lead.

-Then take some scotch tape and rub the sticky side of the tape along the blue plastic boot to remove any dirt or fuzz from the plastic boot. Now clean the meter face and the meter cover (both inside and out) and replace the clear plastic cover by snapping it into place. Apply some scotch tape along the bottom of the meter to seal it from dirt and cover the small hole in the front of the meter housing with the same piece of tape. This edge of the tape should be trimmed with a scissors prior to covering the hole so that it just fits over the hole. Reapply the brown tape to the underside of the meter housings (acts to baffle the light) and put everything back together (don't forget to reattach the connectors to the speaker and VERY gently tighten the handle cover screws).

It is important to remember four things:

A. - Don't apply too much heat to the posts.

B. - Don't over tighten the handle cover screws - just very slight pressure or they will crack.

C. - Be very gentle but persistent in removing the blue plastic boots from the old lamps.

D. - If you have no audio from your radio's speaker check that you reattached the speaker leads.

These instructions should get you thru the procedure without a mishap.

73 and good DX and if you need help call 1-954-961-2034 in the evenings.

By the way if you need the photos enlarged contact me via email at "NC4LMal@aol.com" and I can send you the nice large copies.

73 de NC4L

EB5AGV's FT-102 page

Keep them glowing! You find José on his webpage <http://www.jvgavila.com/ft102.htm>

This page is devoted to the Yaesu FT-102 HF amateur bands dual conversion transceiver. It is an hybrid transceiver, as it uses solid state circuitry in all stages except the final power amplifier (3 x 6146B) and driver (12BY7A). Conservatively rated at 100W, it is able to put more than 200W if tuned for maximum output. At 100W you can expect really long life for its power tubes (as a sample, my unit still has the original PA tubes!)



This transceiver was top of the line for Yaesu at the beginning of the eighties and has a reputation of being a solid performer. It can use some optional filters for SSB and CW which along its IF SHIFT/WIDTH control and APF (Audio Pass-band Filter) make it a highly selective and sensitive rig (see table in the Technical Characteristics page). It has plenty of controls, digital frequency display, two panel meters (one is pictured below). Basically, almost everything you could ask for a rig except for computer control, memories and those

digital age advantages. I, personally, can live without all of those :-)

My unit, bought locally in November 1997, was an european marketed Yaesu, so it is called 'Sommerkamp', but it is exactly the same except for the name plate. Serial number is 2K060837. I got my unit with all the optional filters and AM/FM module on it. It has the XF-8.2HC and XF-455C filters for CW, the XF-8.2HSN for narrow SSB and the XF-8.2GA for AM. I should say that this transceiver is one of my favourites.

Please, join us at Yaesu FT-102 Yahooogroup if you are interested in this transceiver ! - Since 2001!

Technical Characteristics

Frequency coverage	All amateur bands from 160 to 10 meters, WARC included		
Operating modes	LSB,USB,CW,AM,FM (AM TX and FM TX/RX with optional module)		
Power requirements	Receive: 95 VA (73 VA with heaters off) Transmit: 440 VA (for 100W output)		
Dimensions	368 x 129 x 309 (mm)		
Weight	15 kg		
TRANSMITTER			
Carrier suppression	Better than -40dB at 14MHz		
Sideband suppression	Better than -60dB (14MHz, 1 kHz tone)		
Spurious radiation	Better than -40dB		
Third order IMD	Better than -40dB (14MHz, 100W PEP)		
Negative feedback level	Approx. -6dB at 14MHz		
Frequency stability	Less than 300Hz drift during first 30 minutes after 10 minutes warm-up. Less than 100Hz every 30 minutes thereafter		
Microphone input impedance	Low, 200 to 600 Ohm		
RECEIVER			
IF frequencies	8.2MHz and 455kHz		
Image rejection	Better than 70dB from 1.8 to 21.5MHz, Better than 50dB from 24.5 to 29.9MHz		
IF rejection	Better than 70dB		
AF output	1.5W minimum (8 Ohm, 10% THD)		
AF output impedance	4 to 16 Ohm		
Selectivity (-6dB/-60dB)	SSB, CW, AM: 2.7/4.8kHz, Width adjust continuously from 2.7kHz to 500Hz		
*Options	SSB nar, CW wide: 1.8/3.1 kHz (XF-8.2HSN filter), CW nar: 600/1300 Hz (XF-8.2HC filter) CW nar: 300/800 Hz (XF-8.2HCN filter), CW nar: 500/1000 Hz (XF-455C filter) CW nar: 270/600 Hz (XF-455CN filter), AM: 6/12.4 kHz (XF-8.2GA filter)		
IF notch depth	Better than 40dB		
Sensitivity (worst case in uV for 10dB (S+N)/N, except FM)	SSB (no optional filters)	RF AMP ON: 0.25,	RF AMP OFF: 1.0
	CW (no optional filters)	RF AMP ON: 0.18,	RF AMP OFF: 0.7
	AM (no optional filters)	RF AMP ON: 1.0 ,	RF AMP OFF: 4.0
	FM (for 20dB quieting)	RF AMP ON: 0.4 ,	RF AMP OFF: 3.0
	CW (with APF ON)	RF AMP ON: 0.05,	RF AMP OFF: 0.2
	SSB (with XF-8.2HSN)	RF AMP ON: 0.2 ,	RF AMP OFF: 0.8
	CW (with XF-8.2HSN)	RF AMP ON: 0.12,	RF AMP OFF: 0.5
	With no optional filters	RF AMP ON: 90dB,	RF AMP OFF: 95dB
	With XF-8.2HC filter	RF AMP ON: 95dB,	RF AMP OFF: 100dB
	With XF-8.2HCN filter	RF AMP ON: 97dB,	RF AMP OFF: 102dB
Dynamic range (with IF WIDTH control at maximum)			

This manual is a courtesy to you from **Fox-Tango International**, with contributions from Carol W4CLM, Mal NC4L, José EB5AGV, Wim PA0PGA, and many other FT-102 lovers.

EB5AGV's FT-102 relay substitution TUTORIAL

One of the best known troubles of the FT-102 is the long term life of its relays. All FT-102s are at least 15 years old. Relay technology (and prices!) has changed a lot in these years. The standard FT-102 relays were made by Fujitsu (except for RL01 in the Relay Unit) and were not sealed. So dust could get into them and, finally, make them fail. You can easily find if your FT-102 has flacky relays: when you go from transmit to receive and you get a deaf receiver, that is!. Also, if you toggle the RF amplifier you could get similar results. There are some relays which do other tasks in the rig, as RL01 in the IF Unit, which switches the S-meter from receiving signal level (RX mode) to ALC (TX mode), RL01 in the Local Unit, which works on the CLAR circuit (if it fails, frequency will jump from some Hz to full kHz). So, any sign of these troubles is indication of a relay failure.

Cleaning the relays is just a temporary solution which does not last long, so I recommend changing all the relays same time. I have done it myself in the first FT-102 unit I had and it was a four hours work. I have also done my second unit with excellent results.

For replacement I used OMRON relays. All the FT-102 relays have an OMRON equivalent (sealed and with better electrical characteristics than original ones) EXCEPT for one relay, which had a very curious (and exclusive) pinout (shown in a picture later). So curious that the only way to replace it is making an adaptor with an IC socket and some rewiring in the PCB. By the way, Fujitsu, the original manufacturer of the FT-102 relays, still manufactures some of them but I won't buy again the non sealed relays and will get the OMRON or Fujitsu sealed types. Price difference is really low and sealed relays will last lots more. For your reference, a complete OMRON relay set was about \$45 (back in 2000; now some of the relays are obsolete types), here in Valencia. Slight differences in nomenclature of the relays (as G2E-184PM/12 and G2E-184PHM/12) are not a trouble; in fact, the references I have put in the table are the ones I was able to locate here in the OMRON Valencia branch.

The relays which are more prone to fail are the smaller (low signal relays) so I recommend changing all of them and then checking for correct operation before changing RL01 in the Relay Unit.

FT-102 Relay Substitution Table

<i>Board or Reference</i>	<i>Original relay</i>	<i>OMRON replacement</i>	<i>Fujitsu replacement</i>
RF Unit (PB-2342)			
RL01, RL03	FBR211A DO12-M	G2E-134PHM/12 or G2E-184PM/12	FBR211-NAD-012-P
RL02	FBR221A DO12	G6A-234P ST US/12 (needs rewiring)***	
RL04, RL05	FBR211A DO24-M	G2E-134PHM/24 or G2E-184PHM/24	FBR211-NAD-024-M
IF Unit (PB-2343)			
RL01	FBR211A DO12-M	G2E-134PHM/12 or G2E-184PM/12	FBR211-NAD-012-P
Local Unit (PB-2345)			
RL01	FBR211A DO12-M	G2E-134PHM/12 or G2E-184PM/12	FBR211-NAD-012-P
Final Board (PB-2355)			
RL01	FBR211A DO12-M	G2E-134PHM/12 or G2E-184PM/12	FBR211-NAD-012-P
Relay Unit (PB-2354)			
RL01	OMRON G2U-112P/10V	G8SN-1C7-CUK/12	

MOST OF THESE RELAYS ARE NOW OBSOLETE BUT SOME CAN STILL BE BOUGHT AT RS-COMPONENTS

TUTORIAL

These are the compiled notes and pictures I took in my last FT-102 repair. I got this nice unit still fitted with the original relays. As expected, unit had the well known troubles with them, so I got a new batch of OMRON relays and saved them for future use... Finally, I was able to accomplish the task. All the work, done very carefully, was about four hours. It can be done in less time but, as this repair should last several years, it pays to do it without hurry. Anyway, this is a hobby! Well, first step is to undress the rig (i.e. pull out covers). First the top cover and then the bottom one. Setup a good workbench space. A desoldering station (mine is shown in the picture) is a really nice tool for this work.



FT-102 in the workbench

Put the rig upside down, as shown below.

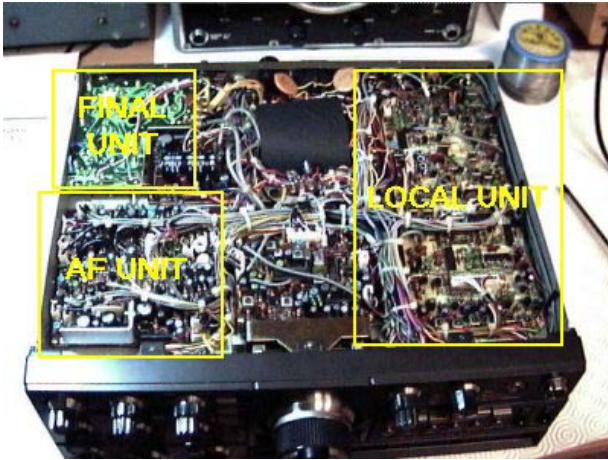

FT-102 upside down

RF UNIT RELAYS

We will start with the most conflictive relays, those in the RF unit. In order to access to the solder side of this unit, we will remove the AF unit (4 screws) and the RF unit shield (2 screws). Then put the rig over its side, with the AF unit hanging on its wires.



FT-102 ready to start repair

We need to locate the relays in the RF unit. Here you have them (looked from the component side of the RF unit):



RL1001 and 1002

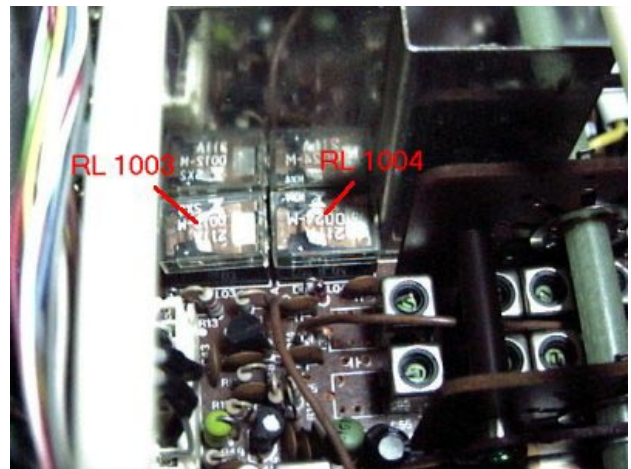

RL1003 and 1004

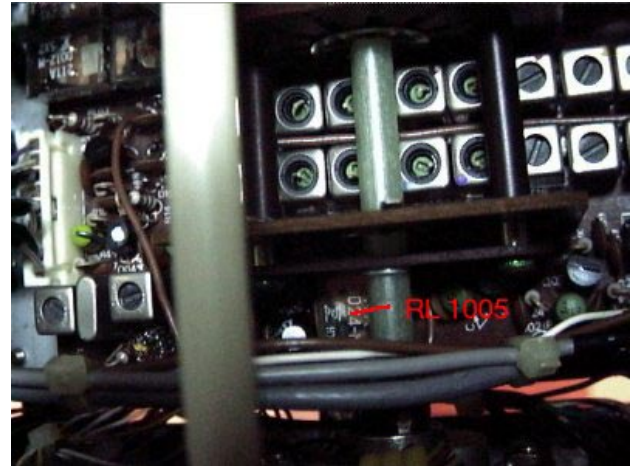

RL1005

Replace RL1001, 1003 and 1004, which are easy to access. Note that the last one is 24VDC.

As you can see, RL1005 is almost hidden by a rotary switch (attached to the BAND knob). In order to change it, we will need to unsolder this rotary switch along a bridge which is just over it:

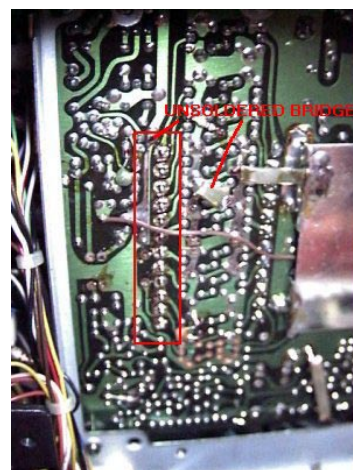

Unsoldering to access RL1005

Then unsolder all the pins of the relay and carefully pull the rotary switch to free it. This could take some time... patience pays!.

In order to replace RL1002, as it is a non-standard relay, it is better to build an adapter, based on a standard 16 pin DIL socket and then just rewire some PCB traces.

IMPORTANT: USE THE SHORTEST POSSIBLE LENGTH OF WIRING AND; IF AVAILABLE; USE SMALL GAUGE COAX.

Here you have the pictures to do this:

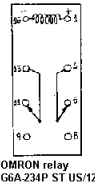
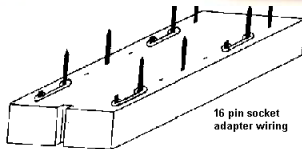

RL1002 replacement (I)

RL1002 replacement (Ib)

This picture shows the wiring of the socket adapter, based on a 16 pin DIL socket and also the internal configuration of the original and replacement relays.

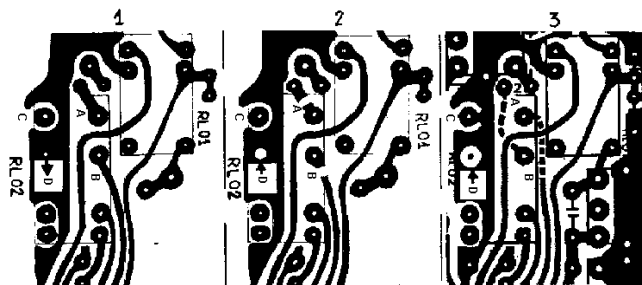

RL1002 replacement (II)

Here you have the necessary changes to do in the PCB. In figure 1 you have the original PCB traces. Cut the traces at points 'A' and 'B', as shown in the figure 2. Then put wire bridges as shown in figure 3 (discontinued lines), crossing 'A' and 'B' and then another one in 'C'. Enlarge hole 'D' to prevent contact with this pin. Put the socket adapter and plug the OMRON G6A-234P relay on it. Then, the connection which was soldered to point 'C' goes now to point 'D'. Here you have a picture of the modified zone:

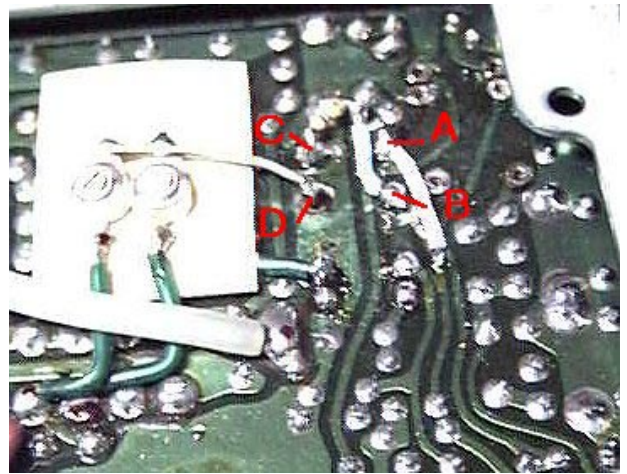

RL1002 replacement (III)

You can now resolder the rotary switch and put the RF cover and AF units back. Once done, you can check the rig. Most of the relay problems should be gone by now!

LOCAL UNIT RELAY

The LOCAL unit is also accessible from the bottom side. This unit has only one relay which serves to switch the CLARifier. So when it fails, you will get nice frequency jumpings in CLAR mode... Not too fine!.

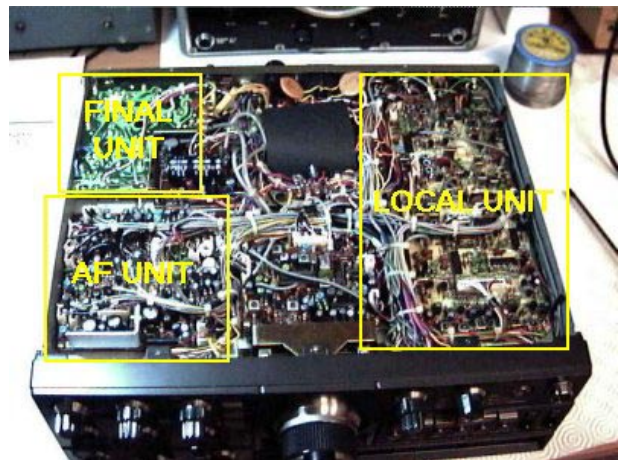

FT-102 upside down

Get out the 7 screws and unplug all the connectors. BEWARE: my unit have three soldered wires which are attached to the LOCAL unit. I managed to change the relay without unsoldering them, but you should be careful in order to keep them unbroken.

FINAL UNIT RELAY

This unit is also accessible from the bottom side and has only one relay which seems to switch some PA tubes control voltages.



FINAL unit relay

In order to save lots of time opening PA cage, removing tubes and so on, you can try to get out the relay without dismantling the board. I did that way and it was just a 20 minutes job.

IF UNIT RELAY

Put the rig in its standard position, so you can access to the upper side.

The IF unit has only one relay. This unit is the one which holds all the standard and optional filters. The relay is located side by side to the 455kc filters (near the back of the rig), hidden below a bunch of wires.

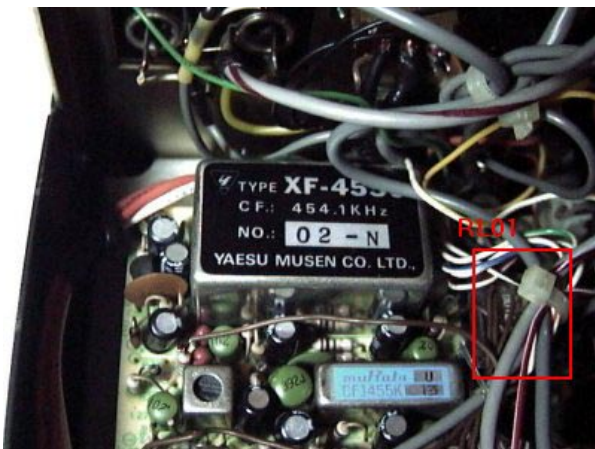

IF unit relay

If it fails, you will get jumpings in the S-meter indication on receive and ALC on transmit, but it will affect only to the meter, not to the real signals. Anyway, it is worth changing it. You will need to unplug all the connectors in the IF unit (a LOT of them, really!). Be VERY careful with the coaxial connectors. Pull them from the metal part, NOT from the cable, as it is delicate. Write down the colors of the coaxial wires and its location (a fast sketch is just fine). Once you have done that, get out the 6 screws and carefully remove the IF unit. Change the relay and put it back in reverse sequence. Now your S-meter will be fine again!.

Well, I hope these notes could lead to a full working FT-102!. Please, let me know if you have any doubt or comment about the information shown in this page.

NOTE: I DON'T STOCK REPLACEMENT RELAYS, SORRY!

FT-102 Yahoogroup

If you are interested in this transceiver, please, join us at: <http://groups.yahoo.com/group/ft102/>

Since 2001!

EB5AGV's FT-102 Power Amplifier tuning

As most tubed power amplifiers (one exception is the Central Electronics CE-100V and CE-200V), the FT-102 PA should be tuned to work. Here you have a brief guide to do this. I have extracted this information from the User's Manual and has worked for me all right. I keep a copy of this information just below the rig, for fast access when I switch from another transmitter (not all are the same!)

- * Select default values for the controls:
 - o MODE: TUNE
 - o LOADING: 0
 - o BAND: desired band
 - o PLATE: pre-select depending on band
 - o DRIVE: 0
- * Connect POWER and HEATER and wait 1 minute
- * Turn the RF AMP ON and find a peak in background noise with PRESELECT
- * Activate PTT momentarily. Ic should be 75 to 80mA
- * Press PTT. Set DRIVE to about 9 o'clock position. Adjust PRESELECT for a peak reading.
- * The following steps should be maximum 5 seconds each:
 - o Activate PTT. Find an Ic DIP with PLATE control. Go back to reception.
 - o Press the PTT. Get an ALC indication of '9' with the DRIVE control.
- * Return to reception.
 - o Put LOADING to '1'. Press PTT. Get an Ic DIP with PLATE. Go back to receiving mode.
 - o Advance the LOADING control slightly and re-DIP with PLATE until the Ic DIP is exactly at 300mA (350mA in 1.8MHz band). The final LOADING position should be close to the table shown in manual (page 24).

Please, let me know if you have any doubt, comment or correction about the information shown in this page.

73, José, EB5AGV



The 6146 Family of Tubes

by

Glen E. Zook, K9STH



Probably the most used tube of all times in the final amplifier of "boat anchor" transmitters is the 6146. From the early 1950s until at least the 1980s, the 6146 found its way into virtually every manufacturer's line of transmitters. In fact, during the early 1960s RCA had a series of advertisements on the back cover of QST that listed a different manufacturer's equipment that used the 6146 each month.

There are actually three distinctive variants of the basic 6146: The 6146, 6146A, and 6146B. It is unfortunate that the 6146B was called the 6146B for it is really a different tube from the first two. Primarily the difference between the "plain" 6146 and the 6146A is the makeup of the heater ("filament"). The 6146A has what RCA calls the "dark heater". This "dark heater" is supposed to be more resilient to vibration, work well at a larger "range" of voltage, etc. Otherwise, the 6146 and the 6146A are the same tube.

In mid-1964 RCA introduced the 6146B with the "claim" of 33.33 percent higher power input than the 6146 / 6146A. Also, it was "claimed" that the 6146B could be directly substituted for the earlier tubes. The 6146 / 6146A had a maximum rated power input

Many amateurs are aware that the military "ruggedized" version was designated the 6146W (I will get to these tubes a bit later). However, RCA also introduced in the early 1960s the 8298 tube for use in commercial mobile equipment. The 8298 is just a "heftier" 6146A. Motorola, General Electric, and quite a number of other commercial FM equipment manufacturers used these tubes in all sorts of FM communications equipment for both low band (30-50 MHz) and high band (150.8 - 172 MHz). When the 6146B was introduced, RCA "announced" the 8298A commercial equivalent of the 6146B. In fact, most of the RCA 6146B tubes were "cross branded" with the 8298A number in addition to the 6146B.

Those companies who were manufacturing 6146 series tubes for the military changed from the "plain" 6146 to the 6146A to the 6146B as the military decreed. However, all of the tubes manufactured under military contracts were known as 6146W and, to my knowledge, nothing was done towards marking the tubes as being equivalents of the 6146, 6146A, or 6146B. The only way of telling is from the "date code" which is printed on each tube. Different manufacturers changed tube types at different times. Also, I know of no "master list" telling on what date a particular manufacturer changed from the 6146 to the 6146A to the 6146B. The only "sure" way to know if a particular 6146W is of either the 6146 or 6146A type is to look for a "code date" of before 1964 since RCA introduced the 6146B in the middle of that year. However, some manufacturers did not start manufacturing 6146B equivalent 6146W tubes for at least a year after RCA introduced the 6146B.

RCA "claimed" that the 6146B was directly interchangeable with the earlier members of the 6146 family. Unfortunately, this did not hold true in most cases. Collins, Heath, and probably other companies, at first issued various documents saying that the use of the 6146B in their equipment was "fine". But, this soon proved otherwise!

For example, when the 6146B was used in the Collins 32S-1, 32S-2, 32S-3, 32S-3A, KWM-2, and KWM-2A it was discovered that the components in the neutralization circuitry "burned up" in a very short amount of time. Thus, Collins had to retract the statement that it was "OK" to use the 6146B. Then, due to the fact that the United States military establishment wanted to "standardize" on the 6146W equivalent of the 6146B, the neutralization components had to be redesigned to allow the 6146B to be used. Fortunately, these changes did not affect the use of the earlier 6146 and 6146A in those transmitters manufactured to use the 6146B. All three types of tubes may be used without any problem in these transmitters.

Replacing the 6146 / 6146A tubes with 6146B types often results in spurious emissions, parasitic oscillations, etc. This is due to the fact that there are different bias requirements, different inter-electrode capacitances, etc. of the 6146B versus the other two. It is often difficult to neutralize 6146B tubes when used in place of the 6146 / 6146A. If neutralization can be achieved, often it lasts for just a few minutes before the tube(s) goes into oscillation.

If one insists on trying the 6146B tubes in place of the 6146 / 6146A types, the very first thing to do is to neutralize the final amplifier. If it will not neutralize, then the 6146B tubes should immediately be replaced with the older type tubes. If it does neutralize, then the neutralization should be "watched" for several hours (even days) of operation. If the neutralization changes, then the 6146B tubes again should be replaced with the 6146 / 6146A series. If the neutralization remains constant after several days, then use of the 6146B is fine in that particular transmitter.

I have, in my shack, a number of transmitters that use the 6146 / 6146A type of tubes. These include Collins 32S-1, 32S-3 (earlier model before the neutralization was changed); Heath Apache, DX-100, DX-35, SB-401, SB-110, Seneca; Johnson Pacemaker; and other transmitters as well. Every one of these is much "happier" with the 6146 / 6146A family of tubes. In addition, I have owned transmitters like the Knight T-150 and T-150A that use the 6146 tubes. Frankly, these transmitters were much happier with the 6146 / 6146A tubes.

Many amateurs are aware that the military "ruggedized" version was designated the 6146W (I will get to these tubes a bit later). However, RCA also introduced in the early 1960s the 8298 tube for use in commercial mobile equipment. The 8298 is just a "heftier" 6146A. Motorola, General Electric, and quite a number of other commercial FM equipment manufacturers used these tubes in all sorts of FM communications equipment for both low band (30-50 MHz) and high band (150.8 - 172 MHz).

When the 6146B was introduced, RCA "announced" the 8298A commercial equivalent of the 6146B. In fact, most of the RCA 6146B tubes were "cross branded" with the 8298A number in addition to the 6146B.

Those companies who were manufacturing 6146 series tubes for the military changed from the "plain" 6146 to the 6146A to the 6146B as the military decreed. However, all of the tubes manufactured under military contracts were known as 6146W and, to my knowledge, nothing was done towards marking the tubes as being equivalents of the 6146, 6146A, or 6146B. The only way of telling is from the "date code" which is printed on each tube. Different manufacturers changed tube types at different times. Also, I know of no "master list" telling on what date a particular manufacturer changed from the 6146 to the 6146A to the 6146B. The only "sure" way to know if a particular 6146W is of either the 6146 or 6146A type is to look for a "code date" of before 1964 since RCA introduced the 6146B in the middle of that year. However, some manufacturers did not start manufacturing 6146B equivalent 6146W tubes for at least a year after RCA introduced the 6146B.

RCA "claimed" that the 6146B was directly interchangeable with the earlier members of the 6146 family. Unfortunately, this did not hold true in most cases. Collins, Heath, and probably other companies, at first issued various documents saying that the use of the 6146B in their equipment was "fine". But, this soon proved otherwise!

For example, when the 6146B was used in the Collins 32S-1, 32S-2, 32S-3, 32S-3A, KWM-2, and KWM-2A it was discovered that the components in the neutralization circuitry "burned up" in a very short amount of time. Thus, Collins had to retract the statement that it was "OK" to use the 6146B. Then, due to the fact that the United States military establishment wanted to "standardize" on the 6146W equivalent of the 6146B, the neutralization components had to be redesigned to allow the 6146B to be used. Fortunately, these changes did not affect the use of the earlier 6146 and 6146A in those transmitters manufactured to use the 6146B. All three types of tubes may be used without any problem in these transmitters.

Replacing the 6146 / 6146A tubes with 6146B types often results in spurious emissions, parasitic oscillations, etc. This is due to the fact that there are different bias requirements, different inter-electrode capacitances, etc. of the 6146B versus the other two. It is often difficult to neutralize 6146B tubes when used in place of the 6146 / 6146A. If neutralization can be achieved, often it lasts for just a few minutes before the tube(s) goes into oscillation.

If one insists on trying the 6146B tubes in place of the 6146 / 6146A types, the very first thing to do is to neutralize the final amplifier. If it will not neutralize, then the 6146B tubes should immediately be replaced with the older type tubes. If it does neutralize, then the neutralization should be "watched" for several hours (even days) of operation. If the neutralization changes, then the 6146B tubes again should be replaced with the 6146 / 6146A series. If the neutralization remains constant after several days, then use of the 6146B is fine in that particular transmitter.

I have, in my shack, a number of transmitters that use the 6146 / 6146A type of tubes. These include Collins 32S-1, 32S-3 (earlier model before the neutralization was changed); Heath Apache, DX-100, DX-35, SB-401, SB-110, Seneca; Johnson Pacemaker; and other transmitters as well. Every one of these

is much "happier" with the 6146 / 6146A family of tubes. In addition, I have owned transmitters like the Knight T-150 and T-150A that use the 6146 tubes. Frankly, these transmitters were much happier with the 6146 / 6146A tubes. of 90 watts for CW and SSB operation and the 6146B had a rating of 120 watts for the same emissions.

There is another 6146 family tube that is "superior" for operation at least through 10 meters. That is the 6293. This tube was designed for "pulse" service and is rated at 1-Kilo-watt pulse power input. The primary difference between these and the "normal" 6146 is that the plate is much "heavier" in its construction. Back in the late 1950s and early 1960s we would almost "kill" to get our hands on a pair of these for our DX-100s, etc. The 6293 outlasts the 6146 in "normal" service by at least 5 times and often more than 10 times the life of the tube. These tubes "show up" at hamfests, swap meets, etc., from time-to-time. If you see some of these, definitely "glomp" onto them!

The 12-volt equivalent of the 6146 is the 6883, the equivalent of the 6146A is the 6883A, and the 6146B is the 6883B. Now, there are the tubes that were manufactured for FM commercial service. These series go as follows: 6883, 6883A / 8032, 6883B / 8032A / 8552. Again most of these are "cross branded" with all of the tube numbers that are equivalent.

From 1970 until late 1979 when Motorola went out of the reconditioned equipment business, I owned the Motorola reconditioned equipment center for the south-central United States. We reconditioned Motorola FM equipment for 14 states, everything that Motorola sold reconditioned that was exported, and everything that was sold to the United States Government (this was the height of Viet Nam and the Government did buy reconditioned equipment!).

At that time, the Motrac series of mobile equipment was very popular. Depending on the model, these normally used one, or two, of the 6883A / 8032 tubes. It was only in the very "latest" models (HHT "E" series, LHT series, and MHT series) that Motorola had redesigned the equipment to use the 6883B / 8032A / 8552 tubes. Around late 1976 or early 1977, Motorola decided to eliminate some of the tube types that they were "stocking" at the Schamburg, Illinois, parts depot. Thus, they started shipping 8552 tubes in boxes that were marked as 8032. The Motrac is unique in the fact that you cannot see the tubes when they are in operation (they are enclosed in a metal "heat sink"). In fact, it is difficult to even "tune" a Motrac when the heat sink is not in place.

We went through from 50 to over 100 of the 8032 type tubes per week and within days were "down" to using the 8552 tubes in the 8032 boxes. Within a very few days of starting to use the 8552 tubes we started receiving complaints that virtually every Motrac unit that was received by customers arrived with one, or both, tubes broken. Prior to this we had never had a single complaint. Upon investigation we found that the 8552 tubes had so many parasitic oscillations that they were getting so hot that the glass envelope was being annealed! This was happening within a minute, or two, of tune-up and final quality control. When the radio was subjected to normal vibrations of shipping, the glass envelope of the tubes was being shattered.

This was reported to Motorola. At first they refused to believe us saying that we must have gotten a "bad" shipment of tubes. But, within a couple of weeks they received over 1000

complaints from their service stations about exactly the same problem. It cost Motorola one "heck of a lot" of money to pay the warranty claims because they had tried to "cut costs" by eliminating the earlier type of tube. They had to re-box all of the 8552 tubes that had been put into 8032 boxes and get in a "rush" shipment of 8032 tubes.

The whole problem stemmed from the fact that the "B" series of tubes is not the same as the "plain" and "A" series. The parasitic oscillations were caused by the different bias requirements and by the "fixed" neutralization of the driver and/or amplifier tube in the Motrac. There was no practical way to change the circuitry to handle the "B" series tubes. Also, making such a change would void the "type acceptance" of the units.

In a "practical" sense, it is "OK" to mix 6146 and 6146A tubes since the primary difference is in the design of the heaters. But, NEVER mix 6146 / 6146A tubes with a 6146B! This is really "asking for trouble".

Also, in a number of transmitters and transceivers (especially the Heath SB-Line) the heaters ("filaments") of the pair of 6146 tubes are in series. In these units it is very easy to change the heaters from series to parallel and substitute the 6883 / 6883A / 8032 tubes. The 12-volt equivalent tubes are often available for "pennies" because of the vast number that were used in the commercial FM market. I have done this with my Heath SB-110A and it works "like a champ". If you every want to change back, it is a very simple operation to do so.

I know that there are amateurs who say that they have used the 6146B tubes in place of the 6146 / 6146A without any problems. I can definitely believe that. But, I have seen way too many examples of the 6146B causing problems in relation to the cases in which the substitution has no effect. As I said before, neutralize and keep checking the neutralization for several days if you do replace your 6146 / 6146A tubes with 6146B types. Otherwise, you can find yourself with TVI, "burned out tubes", and other damage to your transmitter.

You must be VERY careful when dealing with the various tubes of the 6146 family, otherwise you just might be in for some very interesting problems. Substitute if you must, but, be aware that you are "treading on thin ice".

Copyright article: Glen E. Zook K9STH, reprinted with his permission, tnx Glen! More interesting articles on his website: <http://home.comcast.net/~k9sth/>



6146' tubes and Equivalents

6146: Anode dissipation **25W**
equivalent with:

6293 (a heavy duty pulse tube, 5-10x longer lasting)

6146A Anode dissipation **25W**
equivalent with:

6146W/7212	6,3V heater
8298	6,3V heater
8552	6,3V heater
QE-06/40	6,3V heater
6883A/8032	12,6V heater
QE-06/40F	12,6 V heater
QE-06/40K	13,8V heater
QE-06/40H	26V heater

(This last ones are European types produced by Philips and Mullard)

6146B Anode dissipation **35W**
equivalent with:

6146W/7212A 6,3V heater
(when produced after 1962, the 6146W is equivalent with 6146B, before that year they are either 6146A or 6146B,s, check the date tag, or compare the anode construction.)

8298A	6,3V heater
YL-1370	6,3V heater
6883B/8032A	12,6V heater
8552A	12,6V heater
YL-1372	12,6V heater

Because Yaesu uses a 12,6 Volt tap on the transformer, its is possible to use 12,6 Volt tubes too, by rewiring the heaters in parallel instead of in series !

73, Wim PA0PGA

FT-102

HF ALL MODE TRANSCEIVER



Join us at Fox Tango International !
<http://foxtango.org>

Fox-Tango International is a club where all users of Yeasu equipment find equally minded hams who help each other to keep their older and newer Yeasu equipment in excellent condition. In our forums we discuss all kinds of problems that arise and ways to solve problems and find solutions for hard to get spareparts and much, much more.

Please visit our website and see for yourself

The membership is free of charge, so join us to keep your Fox Tangos on the air !!

FT-102 Manuals

You can download the FT-102 User and Service Manual direct from the Fox-Tango FT-102 site at: <http://foxtango.org//FT-102/FT-102%20Page.htm> or from: Kevin Withemarsh YAESU manual site, where you will find almost every YAESU manual that you may need. His library website is on: <http://foxtango.ham-radio-op.net/>

Take note: for some of the bigger sized manuals is it necessary that you join the Fox Tango International club, because downloading of them is restricted to members.



YAESU

This manual is a courtesy to you from **Fox-Tango International**, with contributions from Carol W4CLM, Mal NC4L, José EB5AGV, Wim PA0PGA, and many other FT-102 lovers.